

# [thecarversite.com](http://thecarversite.com)

This manual is either an original scan from tech's who worked at Carver corp, donated by forum members, or both. These manuals are NOT intended for re-sale. If you purchased a 'Carver Manuals' disc on ebay or another auction site, and it has this material on it, you were ripped off!

Please report any resale of this material to us at [thecarversite.com](http://thecarversite.com)

# [thecarversite.com](http://thecarversite.com)

7

CARVER CORPORATION  
CT-24 SCHEMATICS

thecarversite.com

## CT-24

|                 |                                |     |
|-----------------|--------------------------------|-----|
| 1102-100044-000 | CAP, LYTIC 10UF 50V +-20%      | 0   |
| 1001-201310-000 | RES, CF 120 OHM 1W +-5%        | 0   |
| 1004-705320-000 | RES, CF 4.7M OHM 2W +-5%       | - 0 |
| 1023-900320-000 | RES, FUSIBLE MO 39 OHM 2W      | 0   |
| 1024-707310-000 | RES, FUS. MO 4.7 OHM 1W +-5%   | 0   |
| 1051-004512-120 | RES, SEMI-FIXED 100KB +-20%    | 0   |
| 1061-004501-110 | VOL W/MOTOR 100KAX2            | 0   |
| 1061-004501-180 | RV162G 100Kx2B W/CENTER CLICK  | 0   |
| 1100-100042-100 | CAP, CER .10PF 50V +-5% SL     | 0   |
| 1100-101043-000 | CAP, CER 100PF 50V +-10%       | 0   |
| 1100-102043-100 | CAP, CER 1000PF 50V +-10% Y5P  | 0   |
| 1100-104044-000 | CAP, CER .1uF 50V +-20%        | 0   |
| 1100-104045-100 | CAP, CER .1UF 50V +80-20% Y5V  | 0   |
| 1100-151043-001 | CAP, CER 150PF 50V +-10%       | 0   |
| 1100-220042-000 | CAP, CER 22pF 50V +-5%         | 0   |
| 1100-220042-001 | CAP, CER 22PF +-5% NPO         | 0   |
| 1100-220042-100 | CAP, CER 22PF 50V +-5% SL      | 0   |
| 1100-221043-000 | CAP, CER 22OpF 50V +-10%       | 0   |
| 1100-223025-100 | CAP, CER .022UF 25V +80-20% Y5 | 0   |
| 1100-270042-100 | CAP, CER .27PF 50V +-5% SL     | 0   |
| 1100-271043-000 | CAP, CER 270PF 50V +-10%       | 0   |
| 1100-330042-000 | CAP, CER 33PF 50V +-5%         | 0   |
| 1100-470042-001 | CAP, CER 47PF 50V +-5% NPO     | 0   |
| 1100-470043-000 | CAP, CER 47PF 50V +-10%        | 0   |
| 1100-472044-100 | CAP, CER 4700PF 50V -20% Y5R   | 0   |
| 1100-473045-100 | CAP, CER .047UF 50V +80-20% Y5 | 0   |
| 1101-102062-000 | CAP, MYLAR .001UF 100V +-5%    | 0   |
| 1101-102062-000 | CAP, MYLAR .001UF 100V +-5%    | 174 |
| 1101-102062-000 | CAP, MYLAR .001UF 100V +-5%    | 226 |
| 1101-103062-000 | CAP, MYLAR .01UF 100V +-5%     | 0   |
| 1101-103062-000 | CAP, MYLAR .01UF 100V +-5%     | 175 |
| 1101-103062-000 | CAP, MYLAR .01UF 100V +-5%     | 184 |
| 1101-10362-000  | CAP, MYLAR .01UF 100V +-5%     | 0   |
| 1101-104062-000 | CAP, MYLAR .1UF 100V +-5%      | 0   |
| 1101-104062-000 | CAP, MYLAR .1UF 100V +-5%      | 176 |
| 1101-104062-000 | CAP, MYLAR .1UF 100V +-5%      | 185 |
| 1101-10462-000  | CAP, MYLAR .1UF 100V +-5%      | 0   |
| 1101-122062-000 | CAP, MYLAR .0012UF 100V +-5%   | 0   |
| 1101-123062-000 | CAP, MYLAR .012UF 100V +-5%    | 0   |
| 1101-124063-000 | CAP, MYLAR .12UF 100V +-10%    | 0   |
| 1101-183062-000 | CAP, MYLAR .018UF 100V +-5%    | 0   |
| 1101-223062-000 | CAP, MYLAR .022UF 100V +-5%    | 0   |
| 1101-392062-000 | CAP, MYLAR .0039UF 100V +-5%   | 0   |
| 1101-472062-000 | CAP, MYLAR 4700PF 100V +-5%    | 0   |
| 1101-683063-000 | CAP, MYLAR .068UF 100V +-10%   | 0   |
| 1102-100014-000 | CAP, LYTIC 10UF 16V +-20%      | 0   |
| 1102-100014-000 | CAP, LYTIC 10UF 16V +-20%      | 229 |
| 1102-100044-000 | CAP, LYTIC 10UF 50V +-20%      | 0   |
| 1102-101013-000 | CAP, LYTIC 100UF 16V +-10%     | 0   |
| 1102-101013-000 | CAP, LYTIC 100UF 16V +-10%     | 112 |
| 1102-101013-000 | CAP, LYTIC 100UF 16V +-10%     | 141 |

## CT-24

|                  |                                |     |
|------------------|--------------------------------|-----|
| 1102-101044-000  | CAP, LYTIC 100UF 50V +-20%     | 0   |
| 1102-107044-000  | CAP, LYTIC 1uF 50V +-20%       | 0   |
| 1102-220014-000  | CAP, LYTIC 22uF 16V +-20%      | 0   |
| 1102-220014-000  | CAP, LYTIC 22uF 16V +-20%      | 231 |
| 1102-221034-000  | CAP, LYTIC 220UF 35V +-20%     | 0   |
| 1102-222034-000  | CAP, LYTIC 2200UF 35V +-20%    | 0   |
| 1102-227044-000  | CAP, LYTIC 2.2UF 50V +-20%     | 0   |
| 1102-330004-000  | CAP, LYTIC 33uF 10V +-20%      | 0   |
| 1102-331013-000  | CAP, LYTIC 330UF 16V +-10%     | 0   |
| 1102-470014-000  | CAP, LYTIC .47uF 16V +-20%     | 0   |
| 1102-470024-000  | CAP, LYTIC 47UF 25V +-20%      | 0   |
| 1102-470024-000  | CAP, LYTIC 47UF 25V +-20%      | 186 |
| 1102-471014-000  | CAP, LYTIC 470uF 16V +-20%     | 0   |
| 1102-471025-000  | CAP, LYTIC 470UF 25V +80% -20% | 0   |
| 1102-477043-000  | CAP, LYTIC 4.7UF 50V +-10%     | 0   |
| 1102-477043-000  | CAP, LYTIC 4.7UF 50V +-10%     | 179 |
| 1102-477044-000  | CAP, LYTIC 4.7uF 50V +-20%     | 0   |
| 1102-688044-000  | CAP, LYTIC .68uF 50V +-20%     | 0   |
| 1105-100024-000  | CAP, NON-POLAR. 10UF 25V +-20% | 0   |
| 1105-337024-000  | CAP NON-POLAR. 3.3UF 25V +-20% | 0   |
| 1109-681042-000  | CAP, POLYSTYRENE 680PF +-5%    | 0   |
| 1110-103094-000  | CAP, X-TYPE .01UF AC250V +-20% | 0   |
| 1300-114000-400  | XISTOR DTC114YS                | 0   |
| 1300-114000-400  | XISTOR DTC114YS                | 237 |
| 1300-144000-400  | XISTOR DTC144ES                | 0   |
| 1300-174000-400  | XISTOR 2SC1740S-R.S            | 0   |
| 1300-212000-100  | XISTOR, NPN C2120Y TO-92 CT4   | 0   |
| 1300-227840-415  | XISTOR, NPN 2SC2784-E NEC      | 0   |
| 1300-245800-100  | XISTOR 2SC2458                 | 0   |
| 1300-278600-400  | XISTOR, 2SC2786-K.L.M.         | 0   |
| 1300-294500-103  | XISTOR NPN 2SC945              | 0   |
| 1300-805000-100  | XISTOR, NPN8050D TO92 SAMSUNG  | 0   |
| 1301-114000-100  | XISTOR DTA114YS                | 0   |
| 1301-114000-100  | XISTOR DTA114YS                | 114 |
| 1301-114000-100  | XISTOR DTA114YS                | 241 |
| 1301-992000-100  | XISTOR, 2SA992F                | 0   |
| 1401-140020-000  | DIODE RECTIFIER 1N4002         | 0   |
| 1401-140020-000  | DIODE RECTIFIER 1N4002         | 146 |
| 1401-141480-000  | DIODE, 1N4148                  | 0   |
| 1401-141480-000  | DIODE, 1N4148                  | 147 |
| 1401-14180-000   | DIODE 1N4148                   | 0   |
| 1402-240001-200  | DIODE, ZENER DZ24V             | 0   |
| 1402-471201-200  | ZENER DIODE 4.7V 1/2W          | 0   |
| 1402-620001-200  | DIODE, ZENER 6.2V 1/2W         | 0   |
| 1404-113301-400  | DIODE, ISS133                  | 0   |
| 1600-230402-000  | CRYSTAL 2.304M +-30PPM CT24    | 0   |
| 1600-230402-000  | CRYSTAL 2.304M +-30PPM CT24    | 348 |
| 1600-720002-000  | CRYSTAL 7.200MHZ HC-49/U HC49U | 0   |
| 1602-8000002-000 | REASONATOR 8.0MHZ              | 0   |
| 1603-107003-990  | CERAMIC FILTER SFE10.7MS2H-A   | 0   |
| 1603-456001-990  | CERAMIC FILTER CSB456F15 FM-   | 0   |

|                 |                                  |     |
|-----------------|----------------------------------|-----|
| 1606-107003-990 | CER FILTER CDA10.7MG46-A FM DE   | 0   |
| 2300-003001-000 | STRAIGHT CONN WAFER 3PIN 2MMP    | 0   |
| 2300-003911-004 | - RCA JACK 2P RJ-1041-08-5 WH/RE | 0   |
| 2300-004001-000 | STRAIGHT CONN WAFER 4PIN 2MMP    | 0   |
| 2300-004001-000 | STRAIGHT CONN WAFER 4PIN 2MMP    | 188 |
| 2300-004001-000 | STRAIGHT CONN WAFER 4PIN 2MMP    | 189 |
| 2300-004010-000 | R ANGLE CONN WAFER 4PIN 2MMP     | 0   |
| 2300-005001-000 | STRAIGHT CONN WAFER 5 PIN 2MMP   | 0   |
| 2300-005001-000 | STRAIGHT CONN WAFER 5 PIN 2MMP   | 190 |
| 2300-010001-000 | STRAIGHT CONN WAFER 10PIN 2MMP   | 0   |
| 2300-010001-000 | STRAIGHT CONN WAFER 10PIN 2MMP   | 247 |
| 2320-009901-001 | HEADPHONE JACK 6.4MMSTEREO       | 0   |
| 2330-003911-007 | - RCA JACK RJ1042-09-050EA       | 0   |
| 2330-003911-008 | - RCA JACK RJ1043-09-050EA       | 0   |
| 2330-003911-014 | -RCA JACK 2P RJ-1041-09-05EA     | 0   |
| 2330-003911-020 | - RCA JACK RJ-1078 (WELL LONG)   | 0   |
| 2330-003911-021 | - RCA JACK RJ-1086               | 0   |
| 2399-001901-000 | ANTENNA TERMINAL AJ-2031-040     | 0   |
| 2400-020200-001 | TACT SW 2P2T KPT-1105B (9.5MM)   | 0   |
| 2503-032601-041 | CABLE, 3PIN 260MM 1CONN FLAT     | 0   |
| 2503-040801-041 | CABLE, 4PIN 80MM 1CONN FLAT      | 0   |
| 2503-042101-041 | CABLE, 4PIN 210MM 1CONN FLAT     | 0   |
| 2503-052101-041 | CABLE, 5PIN 210MM 1CONN FLAT     | 0   |
| 2503-052601-041 | CABLE, 5PIN 260MM 1CONN FLAT     | 0   |
| 2503-054001-041 | CABLE, 5PIN 400MM 1CONN FLAT     | 0   |
| 2503-101001-041 | CABLE, 10PIN 100MM 1CONN FLAT    | 0   |
| 2503-102101-041 | CABLE, 10PIN 210MM 1CONN FLAT    | 0   |
| 2503-102801-041 | CABLE, 10PIN 280MM 1CONN FLAT    | 0   |
| 2503-106001-041 | CABLE, 10PIN 600MM 1CONN FLAT    | 0   |
| 2600-101002-000 | JUMPER WIRE 100MM 22AWG UL1015   | 0   |
| 2600-101002-800 | JUMPER WIRE 100MM 22AWG UL1015   | 0   |
| 2610-221000-000 | POWER CORD 2100MM POLORIZED      | 0   |
| 2616-000009-900 | FM ANTENNA WIRE, 300 OHM BAL.    | 0   |
| 3001-191000-000 | INFRARED SENSOR SBX1910-52       | 0   |
| 3100-120000-001 | LED, INFRARED EL-1L2 CT24        | 0   |
| 3100-252540-000 | LED RED COLOR ROUND HEAD DIA.    | 0   |
| 3105-090500-000 | VFD SAMSUNG SVA-09MS05           | 0   |
| 3200-570000-010 | EI-57 120VAC                     | 0   |
| 3201-000000-003 | FM ANTENNA MATCHING COIL         | 0   |
| 3206-071030-500 | F.T. MPX ADJ S-071-030 SUMIDA    | 0   |
| 3206-092300-001 | F.T. AM/OSC AT-0923-1 SUMIDA     | 0   |
| 3206-167320-500 | CF-FT S-167-3246 SUMIDA AF IF    | 0   |
| 3206-532700-500 | F.T. LPF 5327-H020 SUMIDA 19KH   | 0   |
| 4002-000000-000 | AM LOOP ANTENNA AJ2017-1         | 0   |
| 4030-000000-000 | FUSE, 5ST 1.6A 250V 20mm         | 0   |
| 4031-201000-000 | FUSE CLIP BEL FC201              | 0   |
| 4041-210000-000 | FM FRONT END PACK TFFJ2UI        | 0   |
| 4050-000000-000 | RELAY (OMRON) G5PES-1 DC12V      | 0   |
| 4071-030300-000 | AC OUTLET AC-T03FB03             | 0   |
| 4090-150000-004 | BATTERY AA UM-3 1.5V METAL CAN   | 0   |
| 4116-410002-500 | IC LB1641 SIL (SANYO)            | 0   |

## CT-24

|                   |                                |     |   |  |
|-------------------|--------------------------------|-----|---|--|
| 4118-320012-500   | IC LA1832 AM/FM IF.MPX SANY DI | 0   |   |  |
| 4120-680051-600   | IC, NJM2068 DIP JRC            | 0   |   |  |
| 4140-660050-000   | IC, CD4066 DIP                 | 0   |   |  |
| 4145-580050-002   | IC, NJM4558M DIP NJRC          | 0   |   |  |
| 4145-580050-002   | IC, NJM4558M DIP NJRC          | 180 |   |  |
| 4145-600050-000   | IC, BA4560 DIP                 | 0   |   |  |
| 4168-705000-000   | IC, MC68H705J1A SOP            | 0   |   |  |
| 4172-180012-500   | IC LC7218 PLL (SANYO) DIP      | 0   |   |  |
| 4173-110051-600   | IC, NJU7311L 28P DIP JRC       | 0   |   |  |
| 4173-130051-600   | IC, NJU7313L 28P DIP JRC       | 0   |   |  |
| 4178-050304-100   | IC 7804 3PIN TO-220 (JRC)      | 0   |   |  |
| 4178-090300-000   | IC LM7809 TO220                | 0   |   |  |
| 4178-150301-800   | IC, LM7815 TO220 NS            | 0   |   |  |
| 4179-150301-500   | IC 7915 T0220 NEC              | 0   |   |  |
| 4187-700123-000   | TMP 87CH70F                    | 0   |   |  |
| 4193-460051-800   | IC NM 93C46N 8P DIP (NATIONAL) | 0   |   |  |
| 4805-010080-002   | REMOTE CONTROL BOARD RC5       | B   | 0 |  |
| 4824-150010-003   | MAIN PCB, CT24                 | C   | 0 |  |
| 4824-150020-001   | HEAD PHONE PCB, CT24           | A   | 0 |  |
| 4824-150040-001   | CONTROL PCB, CT24              | A   | 0 |  |
| 4824-150070-003   | POWER PCB, CT24                | C   | 0 |  |
| 4824-150110-006   | TONE CONTROL PCB, CT24         | F   | 0 |  |
| 4824-150520-003   | VOLUME CONTROL PCB, CT24       | C   | 0 |  |
| 4824-150560-001   | CCA, TUNER, CT-24              | A   | 0 |  |
| 5000-241500-101   | POLYFOAM, R CT24               | 0   |   |  |
| 5000-241500-201   | POLYFOAM, L CT24               | 0   |   |  |
| 5012-050100-200   | EC CARVER MV-5 BRN/BLK         | 0   |   |  |
| 5013-241500-101-1 | BOX, CARTON CT24               | 0   |   |  |
| 5100-241500-100   | IM V/E WHT/BLK A4 CT24         | 0   |   |  |
| 5103-241500-100   | WARRANTY INST. CT24/MV5 GREY/B | 0   |   |  |
| 5103-241500-200   | WARRANTY CARD CT24/MV5 GREY/BL | 0   |   |  |
| 5113-000000-000   | SERIAL NUMBER LABEL, BLANK     | 0   |   |  |
| 5200-080250-030   | POLYBAG 80X250X3C MM CT24      | 0   |   |  |
| 6002-000001-000-5 | COVER, TOP CT24 MV5 RT-02      | 0   |   |  |
| 6002-000002-000-1 | COVER, BOTTOM CT24, MV5 RT-02  | 0   |   |  |
| 6002-000003-000-1 | COVER, BATTERY CT24 MV5 RT02   | 0   |   |  |
| 6003-000008-000-1 | COVER, INLEY RT03 CT24         | 0   |   |  |
| 6005-010011-000   | CDC5 LENS ADAPTOR              | 0   |   |  |
| 6005-010012-000   | CDC5 LENS                      | 0   |   |  |
| 6005-010013-000   | CDC5 HANDLE WASHER             | 0   |   |  |
| 6024-150001-000   | PANEL, FRONT, CT24, 120V       | 0   |   |  |
| 6024-150003-00    | LED LENS, CT24                 | 0   |   |  |
| 6024-150005-000   | KNOB, TREBLE, BASS, BAL, CT24  | 0   |   |  |
| 6024-150006-000   | KNOB, VOLUME, CT24             | 0   |   |  |
| 6024-150008-000   | PCB STAND, LCBS-7, CTR24       | 0   |   |  |
| 6024-150009-000   | PCB STAND, LCBS-22, CT24       | 0   |   |  |
| 6029-010012-000   | PLASTIC FOOT, CT24             | 0   |   |  |
| 6505-010013-000   | HANDLE CDC5, CT24              | 0   |   |  |
| 6511-010009-001   | TERMINAL PLATE CD-P1100        | 0   |   |  |
| 6524-150001-001   | PANEL, FRONT, ALUM. CT24       | 0   |   |  |
| 6524-150002-000-1 | COVER, TOP, PAINTED, CT24      | 0   |   |  |

CT-24

|                   |                                |   |   |
|-------------------|--------------------------------|---|---|
| 6524-150005-000   | BRACKET, HANDLE,CT24           | 0 |   |
| 6524-150006-000-1 | PANEL, REAR, SILKSCREEN, CT24  | 0 |   |
| 6524-150007-002-1 | CABINET, BOTTOM, BLK, CT24     | 0 |   |
| 6524-150008-000   | BRACKET, ANTENNA, CT-24        | 0 |   |
| 6600-010156-000   | CONTACT BATTERY CON. RT02-S001 | 0 |   |
| 6600-010157-000   | CONTACT BATTERY POS. RT02-S002 | 0 |   |
| 6600-010158-000   | CONTACT BATTERY NEG RT02-S003  | 0 |   |
| 6600-020010-000   | PCB MOUNT CD420L01 CT24        | 0 |   |
| 6600-070003-000   | RUBBER PAD, LEG CD90R05        | 0 |   |
| 6600-070012-000   | FOOT, RUBBER FOR XFORMER CT24  | 0 |   |
| 6600-070024-000   | FOOT, RUBBER 12.7X3.5MM CT24   | 0 |   |
| 6600-070029-000   | KEY, FUNCTION: SONIC BUBBING   | 0 |   |
| 6600-070030-000   | AM/FM MODE, P.SCAN MEMORY CT24 | 0 |   |
| 6600-070031-000   | KEY, FUNCTION: PHONO,CD,LD...  | 0 |   |
| 6600-070032-000   | KEY, PRESET CT24               | 0 |   |
| 6600-070033-000   | KEY, TUNING CT24               | 0 |   |
| 6600-070035-000   | KNOB, TREBLE, BASS, BAL CT24   | 0 |   |
| 6600-070036-000   | ENDCAP, R/L CDC5 CT24          | 0 |   |
| 6600-070039-000   | KNOB, OPEN/CLOSE CDC5 CT24     | 0 |   |
| 6600-070040-000   | RING, RUBBER LENS, CDC5 CT24   | 0 |   |
| 6600-070047-000   | KNOB, VOLUME CT24              | 0 |   |
| 6600-070048-000   | KEY PAD, RUBBER CT24           | 0 |   |
| 6600-120030-001   | NUT, HEX M3 M3X5.5X2.4MM CT24  | 0 |   |
| 6600-120040-000   | NUT, SCREW M4X7X3 CT24         | 0 |   |
| 6600-120123-000   | NUT, SCREW M12X3MM             | 0 |   |
| 6600-180007-000   | AC CORD BUSHING PG5RF-5B       | 0 |   |
| 6600-990008-000   | SCREW TERMINAL                 | 0 |   |
| 6600-990011-000   | FILTER, PLASTIC 290X6X0.5MM    | 0 |   |
| 7002-606010-022   | SCREW, M2.6X6 M/C TYPE P/H ZN  | 0 |   |
| 7002-608005-022   | SCREW M2.6X8 P.T.P. P/H A TYPE | 0 |   |
| 7003-006001-111   | SCREW M3X6 S.T.P. B/H (BLK)    | 0 |   |
| 7003-006002-112   | SCREW, M3X6 P.T.P. B/H         | 0 |   |
| 7003-008002-022   | SCREW M3X8 P TYPE P/H ZN       | 0 |   |
| 7003-008002-111   | SCREW, M3X8 P.T.P. B/H (BLK)   | 0 |   |
| 7003-008010-111   | SCREW M3X8 B/H BLACK           | 0 |   |
| 7003-010001-111   | SCREW M3X10 S.T.P. B/H BLK     | 0 |   |
| 7003-010002-111   | SCREW, M3X10 P TYPE B/H BLK    | 0 |   |
| 7003-015002-112   | SCREW M3X15 TYPE B/H ZN PLAT.  | 0 |   |
| 7004-008010-022   | SCREW M4X8 M/C TYPE P/H ZN     | 0 |   |
| 7004-010010-021   | SCREW M4X10 P/H BLK            | 0 |   |
| 7104-010010-022   | WASHER M4X10X1MM               | 0 |   |
| 7112-018006-022   | SCREW WASHER M12X18X0.6MM      | 0 |   |
| 9405-001000-081   | REMOTE CONTROL ASSY CTC5 CT24  | A | 0 |
| 9424-015000-012   | MAIN PCB ASSY, CT24            | B | 0 |
| 9424-015000-022   | HEADPHONE PCB ASSY, CT24       | B | 0 |
| 9424-015000-042   | CONTROL PCB ASSY, CT24         | B | 0 |
| 9424-015000-072   | POWER PCB ASSY 120V ULP CT24   | B | 0 |
| 9424-015000-113   | TONE CONTROL PCB ASSY, CT24    | C | 0 |
| 9424-015000-522   | VOLUME BOARD ASSY, CT24        | B | 0 |
| 9424-015000-562   | TUNER PCB ASSY, CT24           | B | 0 |
| 9624-015000-002   | MECHAN ASSY, CT24              | B | 0 |

CT-24

9724-015000-001  
.9805-030005-002

PACKAGING ASSY (CVR) CT24 A 0  
REMOTE UNIT RT-03 CT24 B 0

thecarversite.com



• This schematic diagram is subject to change without notice in the interests of improved performance.

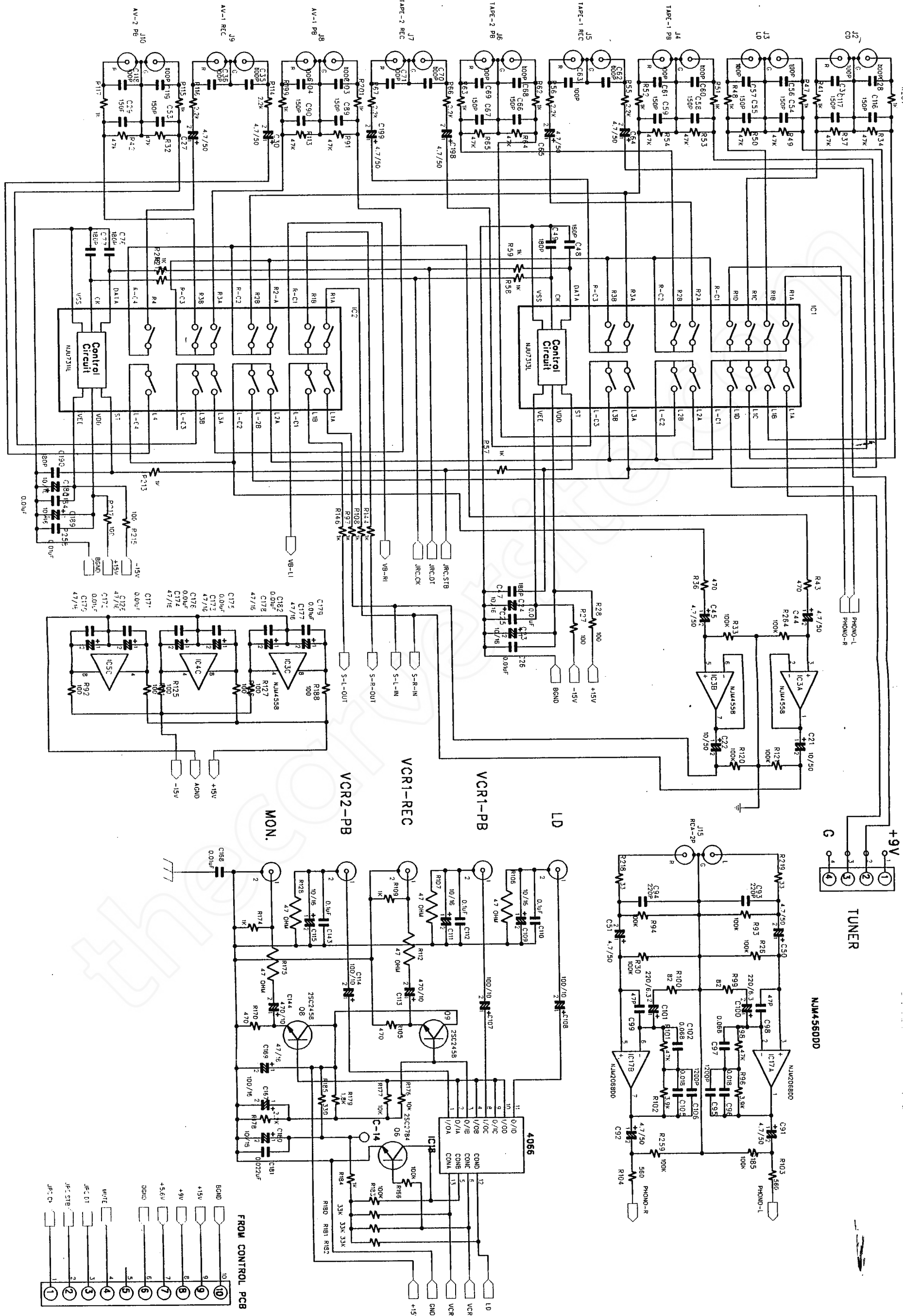

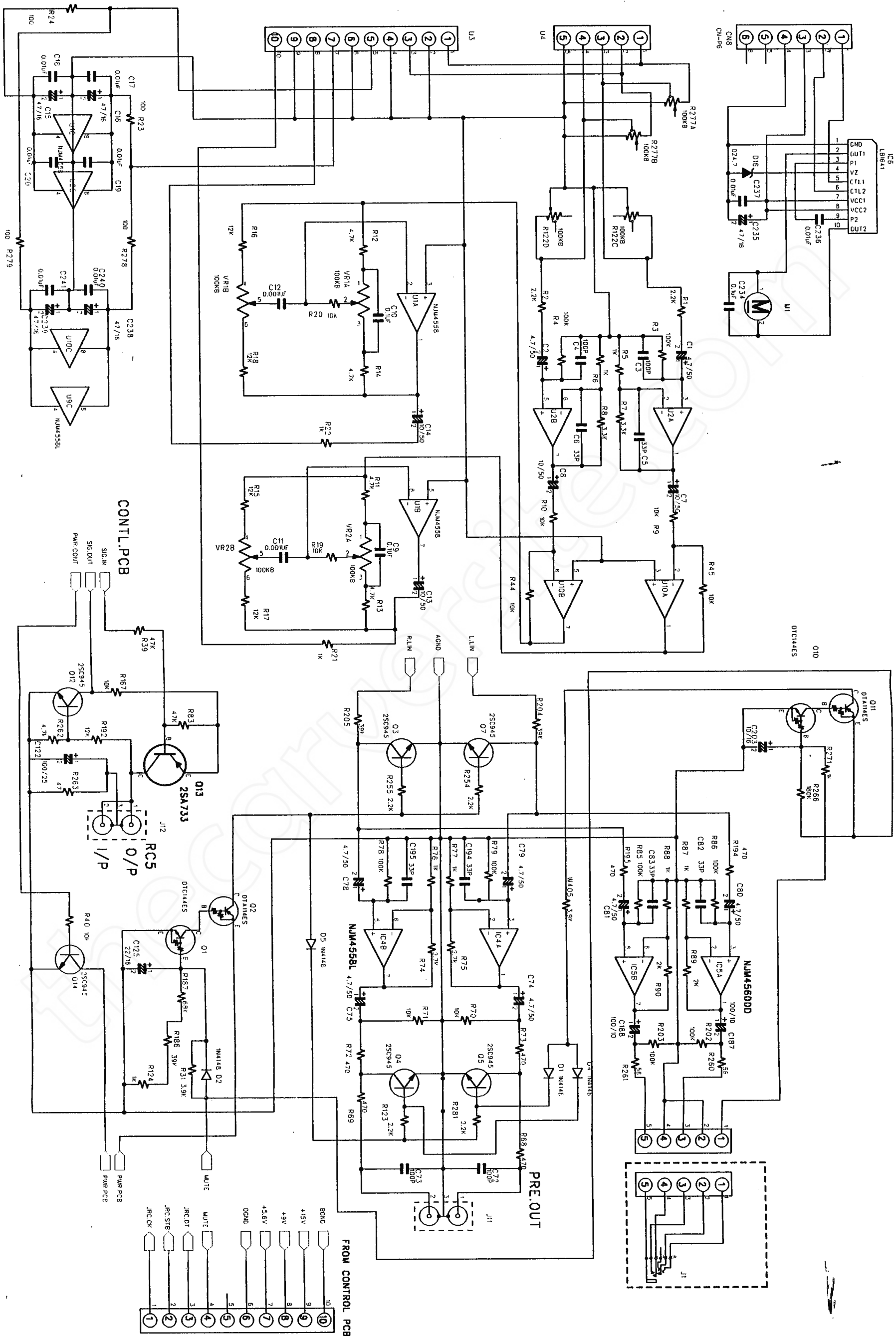

• This schematic diagram is subject to change without notice in the interests of improved performance.

YN

SCHEMATIC DRAWING  
HKNF 960012-00

DATE

MODEL NO : PART NO : PART NAME :

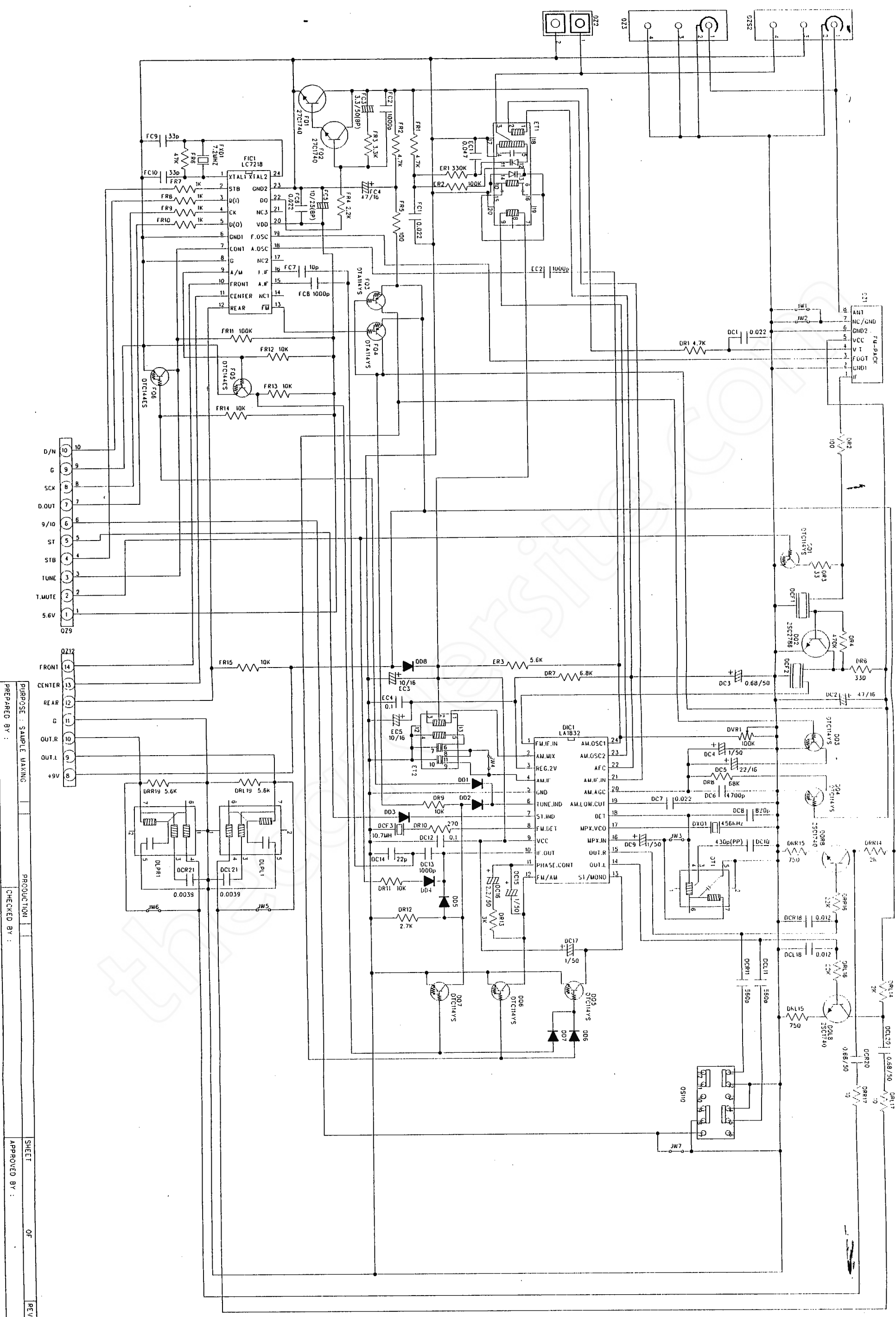

PURPOSE : SAMPLE MAKING  
 PREPARED BY :  
 PRODUCTION :  
 CHECKED BY :  
 SHEET OF REV  
 APPROVED BY :

- 10 D/N
- 9 G
- 8 SCK
- 7 D.OUT
- 6 9/10
- 5 ST
- 4 STB
- 3 TUNE
- 2 T.MUTE
- 1 5.6V
- 14 FRONT
- 13 CENTER
- 12 REAR
- 11 G
- 10 OUT.R
- 9 OUT.L
- 8 +9V

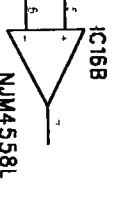
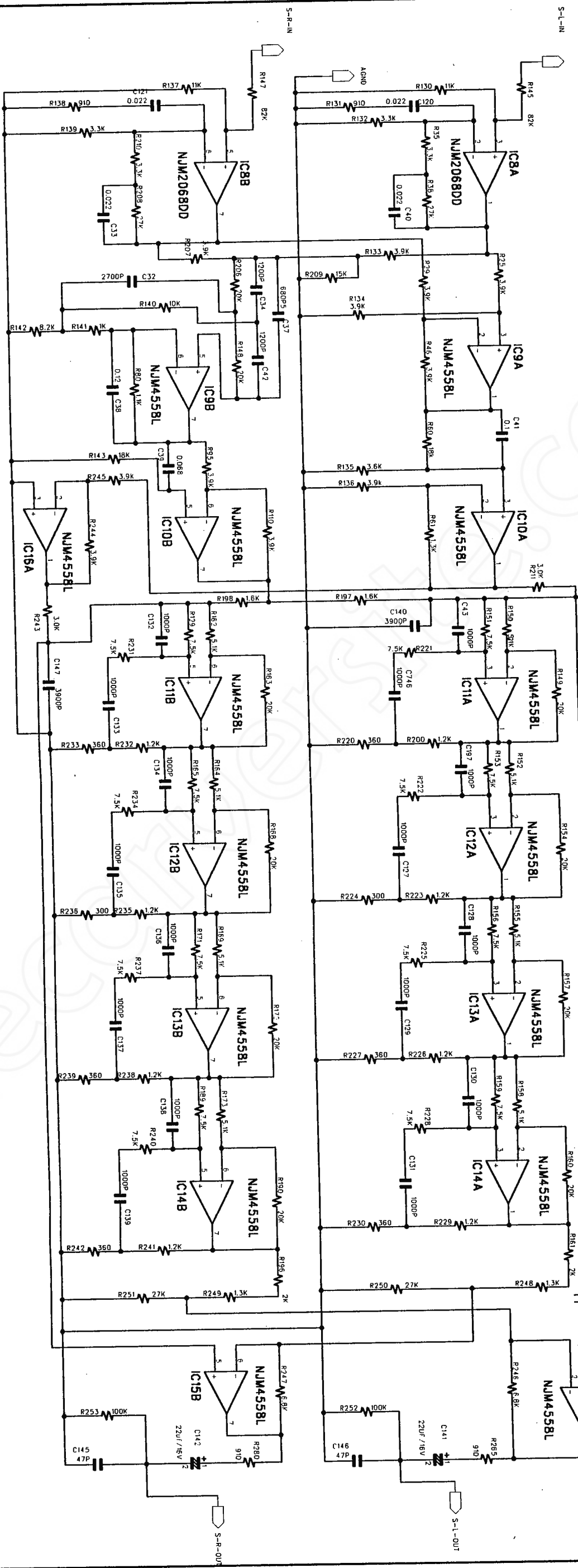
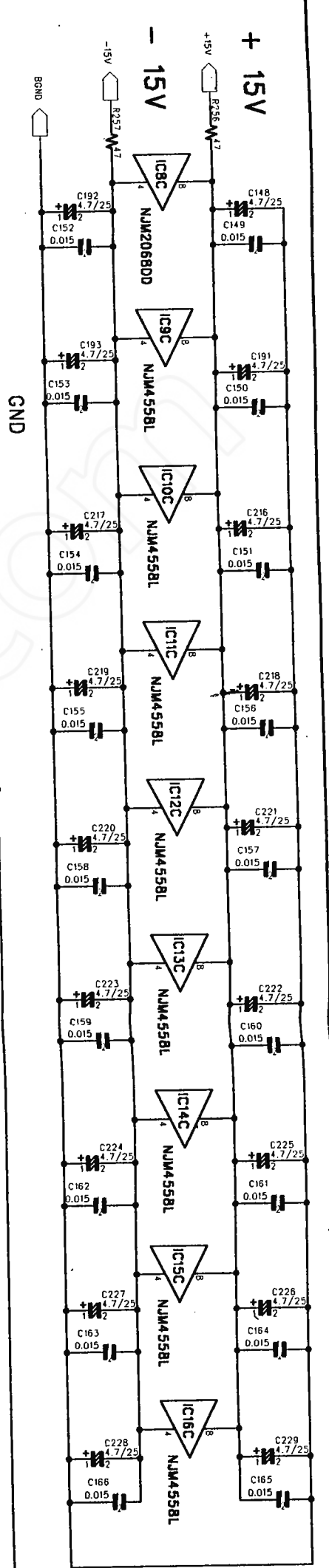

CT-24 Preamp/Tuner

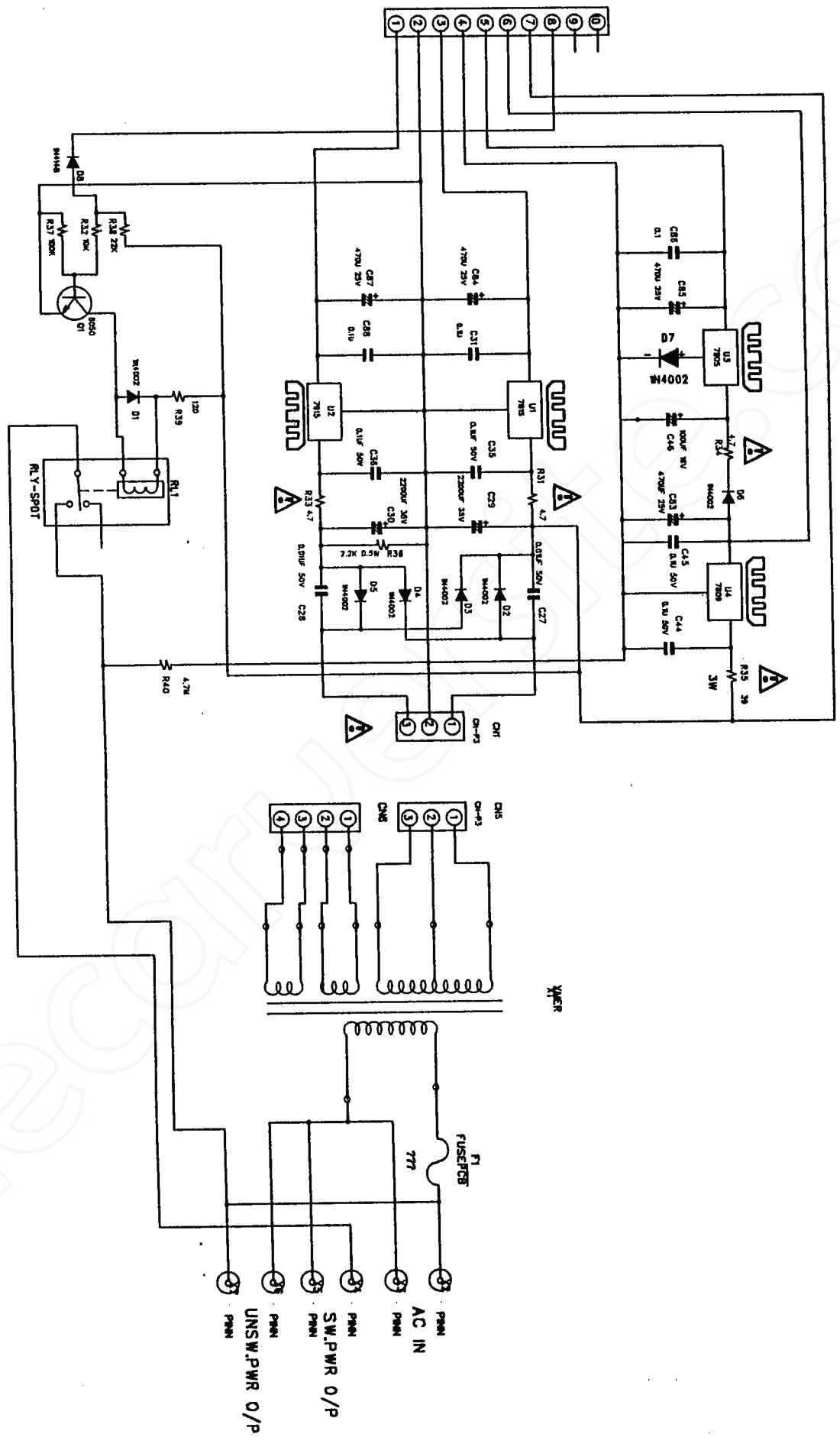

This schematic diagram is subject to change without notice in the interests of improved performance.