CARVER

Powerful · Musical · Accurate

Model PM-2.0t

Magnetic-Field Power Amplifier™

OPERATOR'S MANUAL

TABLE OF CONTENTS

	Page
INTRODUCTION	2
Warranty	
Specifications	
Parts of Your Amplifier	
INSTALLATION	10
Installer's Checklist	
Placement of Amplifier	
AC Connections	
Amplifier Input/Output Connections	
Dual Channel Operation	
Bi-Amplified Operation	
Parallel Mono Operation	
Determining Balanced or Unbalanced Connections	
Balanced Line	
Unbalanced Line	
Speaker Wire	
Initial Powerup	
Fill Out and Mail Warranty Card	
OPERATION	21
Power	
Protection Systems	
MAINTENANCE	23
General	
Troubleshooting	
APPENDIX	27
Conversion to Mono-Operation	

Copyright 1986 by Carver Corporation. All rights reserved.

WARNING: TO PREVENT FIRE OR SHOCK HAZARD, DO NOT EXPOSE THIS EQUIPMENT TO RAIN OR MOISTURE.

TO AVOID ELECTRICAL SHOCK, DO NOT OPEN CHASSIS. NO USER-SERVICEABLE PARTS INSIDE. REFER ALL SERVICING TO QUALIFIED PERSONNEL.

CAUTION: Read and follow all safety and operating instructions.

CARVER CORPORATION LIMITED WARRANTY

NOTICE: the following warranty is exclusive to the United States only. Please see your Carver dealer or distributor for the correct warranty information in your area or locale.

Carver Corporation is proud of its products which have been built with care using advanced technology and premium parts. Your unit has been crafted to perform properly for many years. Carver Corporation offers to you, the owner of a new Carver product, the following warranty:

The Carver Corporation Warranty for each of its products is in effect for one year from the date of original retail purchase. The Carver Corporation Warranty covers defects in materials and workmanship. However, the following are excluded: a) damage caused during shipment, b) damage caused by accident, misuse, abuse or operation contrary to instructions specified in the Carver Corporation owner's manual, c) units where the serial number has been defaced, modified or removed, d) damage resulting from modification or attempted repair by any person other than authorized by Carver Corporation.

The Carver Corporation Warranty extends to the original owner or subsequent owner(s) during the one-year warranty period so long as the original dated purchase receipt is presented whenever warranty service is required.

If your Carver Corporation product ever requires

service, write to or call Carver Corporation (Attention: Customer Service Department), P.O. Box 1237, 20121- 48 Ave W., Lynnwood, WA 98036, (206) 778-0509. You will be directed to an Authorized Carver Corporation Service Station or receive instructions to ship the unit to the factory. Please save the original shipping carton and packaging material in case shipping is required. Please do not ship by Parcel Post. Be sure you have specific authorization from Carver Corporation and include a complete description of the problem, the associated components and connections and a copy of the purchase receipt. Initial costs are not paid by Carver Corporation; return shipping costs will be prepaid if repairs were covered by the scope of this Warranty.

All implied warranties or merchantability and fitness for particular purpose, are limited in duration to the one-year length of this warranty, unless otherwise provided by state law.

Carver Corporation's liability is limited to the repair or replacement, at our option, of any defective product and shall not, in any event include property or any other incidental or consequential damages which may result from the failure of this product.

Some states do not allow limitations on how long an implied warranty lasts and/or do not allow the exclusion or limitation of incidental or consequential damages, so the above limitations or exclusions may not apply to you.

This Warranty gives you specific legal rights, and you may also have other rights which vary from state to state. We suggest that you attach your purchase receipt to this Warranty and keep these in a safe place. Thank you for your choice of a Carver Corporation product.

Carver Corporation
20121 -48th Ave. W.
P.O. Box 1237
Lynnwood, Washington 98036
(206) 778-0509

Congratulations on the purchase of your professional PM-2.0t Amplifier. It represents the latest technology in Carver's patented Magnetic Field Power Supply. This efficient supply coupled with a unique amplifier design provide you with the very best in performance. Because of the specially designed protection systems you can be assured your valuable speakers and amplifier will be protected.

Its mere Ten Pound-weight combined with its rugged construction makes it ideal for touring and permanent installations. We are proud of our track record for excellent performance and proven reliability. The high quality standards Carver products provide is the quality that our customers have come to expect.

A handwritten signature in cursive script that reads "Bob Carver". The signature is written in black ink and is positioned above the printed name.

Bob Carver

SPECIFICATIONS: CARVER PM-2.0t

Power: 8 ohms, 465 w/channel 20-20kHz
both channels driven with no more than 0.5% THD

4 ohms, 600 w/channel 20-20kHz
both channels driven with no more than 0.5% THD

2 ohms 450 w/channel 20-20kHz
both channels driven with no more than .5% THD

Mono Output: 1000 Watts into 4 ohms
THD-less than 0.5% at any power level from 20 mW to clipping

IM Distortion less than 0.1% SMPTE

Frequency Bandwidth: 5Hz-80kHz

Gain: 29 dB

Input Sensitivity: 2.16 Vrms

Damping: 200 at 1kHz

Slew rate: 25V/micro second

Noise: Better than 110dB below 465 watts, A-weighted

Inputs: Balanced to ground, XLR or TRS phone jacks

Input Impedance: 15k ohm each leg to ground

Compatible with 70 V systems

Clipping Eliminator Circuit: Front panel switchable

Mounting: Standard 19" rack with 3.5" spacing

Height: 3.5"

Width: 19"

Depth: (front to back of chassis): 10.75"

Weight: 10 lbs.

FIGURE 1-A

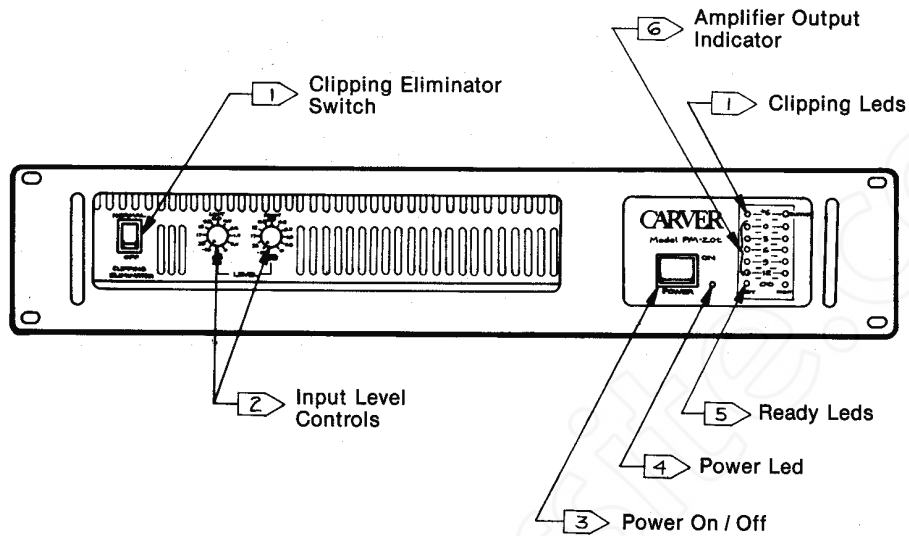

1. CLIPPING LEDS and CLIPPING ELIMINATOR SWITCH

With the Clipping Eliminator switch in the OFF position, the amber clipping LEDS will flash at the point of clipping for either channel. This indicates the amplifier's headroom has been exhausted. Care should be taken not to operate the amplifier in this manner for extended periods of time because of possible speaker damage. With the switch in the Normal position, the amplifier senses output clipping and instantaneously reduces the input gain to prevent high levels of distortion from reaching the loudspeakers. Eliminating clipping distortion also reduces listener fatigue and protects high frequency drivers from distortion products generated when clipping occurs. The Clipping Eliminator efficiently limits amplifier distortion to no more than 1% with input signals of up to 6 dB overdrive. It is strongly recommended the Clipping Eliminator switch stay in the Normal position.

2. INPUT LEVEL CONTROLS

For normal operation both INPUT Level Controls will be fully clockwise. In this position the amplifier's maximum gain of 29 dB is utilized. If lower gain is required, turn the controls counterclockwise. The controls are accurate to within .5 dB. The amount of gain reduction in dB is indicated by 10 calibrated detent positions on the front panel. When the PM 2.0t is used in the parallel mono-mode, only the Left INPUT Level control is active.

CAUTION: If this unit is converted back to stereo operation, the two red output binding posts must NOT be connected to each other.

3. POWER ON/OFF

This switch powers up the amplifier.

4. POWER LED

The red LED is a visual indication that the main power switch is ON or OFF.

5. READY LEDS

The two "Ready" LEDS, when lit, indicate the amplifier is ready for operation. These two LEDS will be on at all times during normal operation.

6. AMPLIFIER OUTPUT INDICATORS

The ten red LEDS indicate calibrated power output for the left and right channels. The LEDS provide a visual indication of power output and remaining headroom for each channel.

FIGURE 1-B

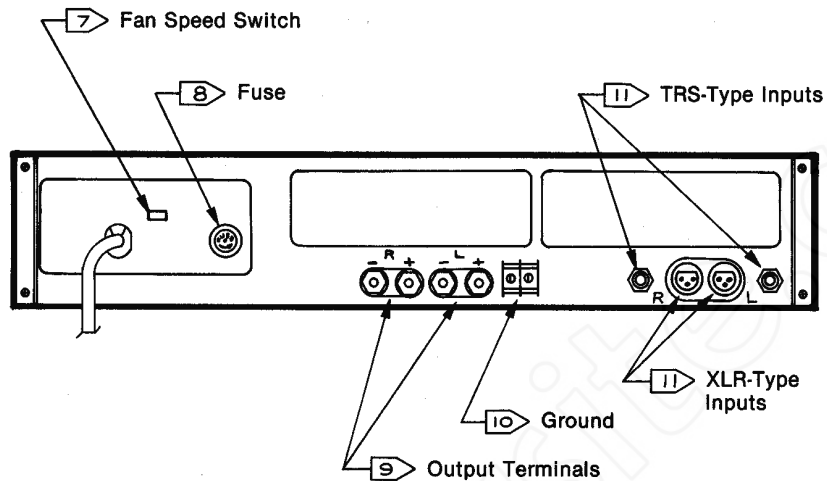

7. FAN SPEED SWITCH

The PM-2.0t cooling fans are switchable for high and low speed operation. For normal use, the fans are left in low speed position. The fan speed is also proportional to the amplifier power output which provides optimum cooling efficiency for the power demands placed on the amplifier.

8. FUSE

REPLACE WITH THE SAME TYPE AND RATING ONLY (MDL 10 or 10A, slo-blo equivalent). The PM-2.0t's fuse type and value allow full dynamic range and allow the amplifier to track the most powerful musical waveforms without compromising the safety of the transformer and power supply circuitry. Never replace the fuse with a different type or rating. Never use a fuse bypass or "cheater". Doing either of these can result in serious amplifier damage and will void the warranty. Make sure the AC line cord is unplugged before replacing the fuse. If the fuse blows immediately after initial replacement, remove the amplifier for servicing.

9. OUTPUT TERMINALS OR BINDING POSTS

The PM-2.0t's speaker connections are two pairs of five-way binding posts that supply output to the loudspeakers for both dual channel and parallel mono operation. The output binding posts accept single-and dual-banana plugs, spade lugs and stripped or tinned leads.

10. GROUND BAR

A small barrier strip provides a means of altering the grounding scheme of the PM-2.0t. When it comes from the factory, a jumper bar connects the amplifier ground to the amplifier chassis. For normal operation the jumper should remain in place. Removing the jumper may be helpful in solving certain ground-loop hum and noise problems. Removing the jumper leaves a 0.15 uf capacitor in parallel with a 27K ohms resistor between the amplifier ground and the chassis.

11. RIGHT/LEFT INPUTS

Signals to drive the PM-2.0t are supplied to either a balanced pair of female XLR connectors or a pair of TRS 1/4-inch phone jacks. Both types of connectors have the same input impedance: 15K ohms each leg balanced to ground for a total input impedance of 30K ohms. The input overload point for the line amplifier is 5 volts RMS. This ensures full compatibility with all modern signal sources, for both input overload and an optimum input signal to noise ratio.

The balanced XLR and TRS inputs allow single-ended (unbalanced) input operation without switches or adaptors. A set of properly wired signal cables is required. See Amplifier Input/Output Connections section. For each channel, the XLR and the TRS input connectors on the PM-2.0t are wired in parallel to allow signals to be passed on when cascading multiple amplifier arrays.

INSTALLER'S CHECKLIST

1. Placement of Amplifier.
2. AC Connections
3. Amplifier Input/Output Connections
4. Initial Power up
5. Fill Out and Mail Warranty Card.

Keep the carton and packing material your amplifier came in. For shipping and service, the best container is the original carton.

1. CHECK PLACEMENT OF AMPLIFIER

If the PM-2.0t is used in mobile sound systems, make sure it is securely rack-mounted.

Air must be free to enter the intake ports on the back panel and exhaust through the front and top panel. In a permanent installation where the PM-2.0t is housed in a special amp room, make sure the room has adequate ventilation.

When mounting equipment in a case or rack, it is a good practice to install the heaviest components in the bottom of the enclosure. This helps stabilize the enclosure during handling.

Mobile Rack Installation

The PM-2.0t is completely rack-mountable and ready to be installed in any standard equipment rack, road/flight case or in any other type of rack mount enclosure.

2. [] AC CONNECTIONS

CAUTION: BE SURE POWER SWITCH IS OFF.

The PM-2.0t should be connected to an AC outlet or receptacle rated for no less than 1500 W. If your sound system uses several amplifiers, then be sure your power bar, outlet strip or special power block can safely handle the total maximum wattage of all the sound system components.

Although output power specifications are conditional to having an AC line voltage of 120V/60Hz (stable), your amplifier will operate on AC lines voltages from 100V to 140V.

If the outlets used to power the system are exposed to foot traffic, secure the plugs to the outlet and the AC line to the wall/floor with tape. This aids in preventing accidental disconnection.

If an extension cord is used, be sure it is the three-prong (grounded) type and 12 gauge or heavier. The longer the extension cord, the heavier the gauge required for safety and minimum line loss.

3. [] AMPLIFIER INPUT/OUTPUT CONNECTIONS

DUAL CHANNEL OPERATION

The PM-2.0t can be used in the conventional stereo mode OR for bi-amplification with a suitable crossover network.

With the power for the PM-2.0t and other components in the system completely off, connect the cables that run from the outputs of the mixer/preamp or crossover to the appropriate left/right channel inputs on the PM-2.0t. Figure 2.

Make sure the connectors are firmly in their respective jacks. Connect the speaker wires from the output terminals of the amplifier to the loudspeakers, being careful to maintain the proper speaker phasing. Figure 2. The PM-2.0t should be connected to loudspeakers with a nominal impedance of 4-ohms or greater.

For stereo operation, the left and right main outputs of the mixing console are connected to the left and right channel inputs respectively. Figure 2.

FIGURE 2
DUAL CHANNEL OPERATION

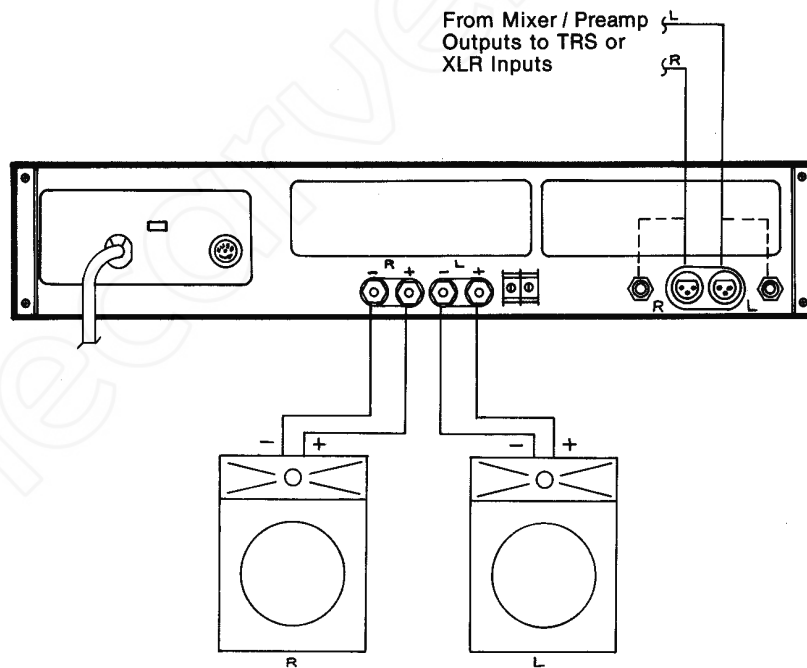

BI-AMPLIFIED OPERATION

If your sound system uses bi-amplified loudspeakers, make connections from the high frequency output of the crossover to the amplifier used for the high frequency drivers. Connect the low-frequency output of the crossover to the amplifier driving the low frequency speakers. Figure 3.

If the PM-2.0t is used to drive a single bi-amplified speaker system, the low/mid-range drivers should be connected to the left channel and the high frequency drivers should be connected the right channel.

FIGURE 3
BI-AMPLIFIED OPERATION

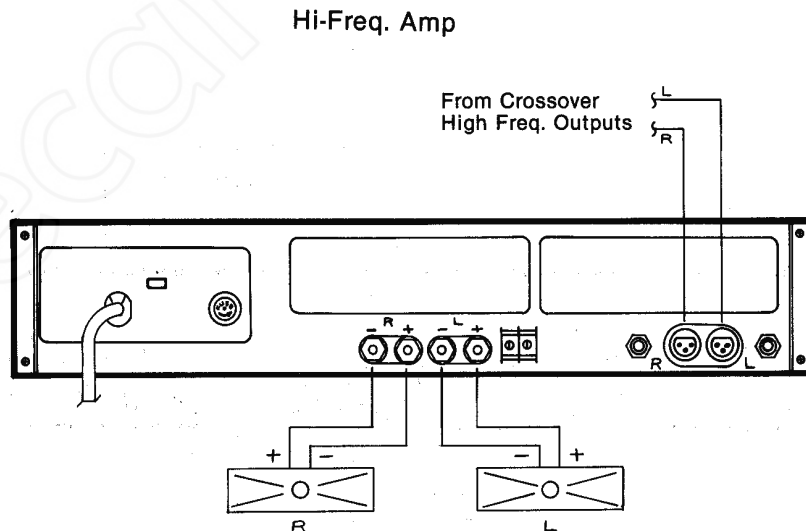

LO-FREQ. AMP

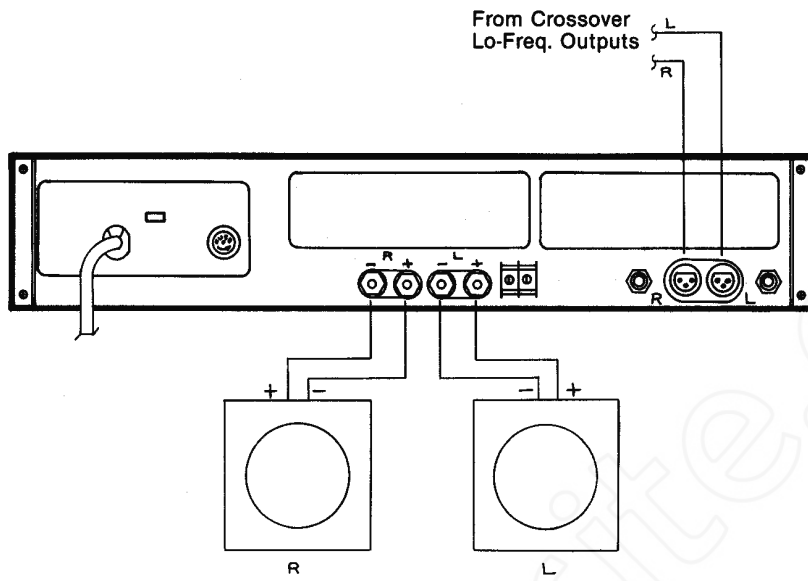

BI-AMPLIFIED OPERATION USING ONE AMPLIFIER

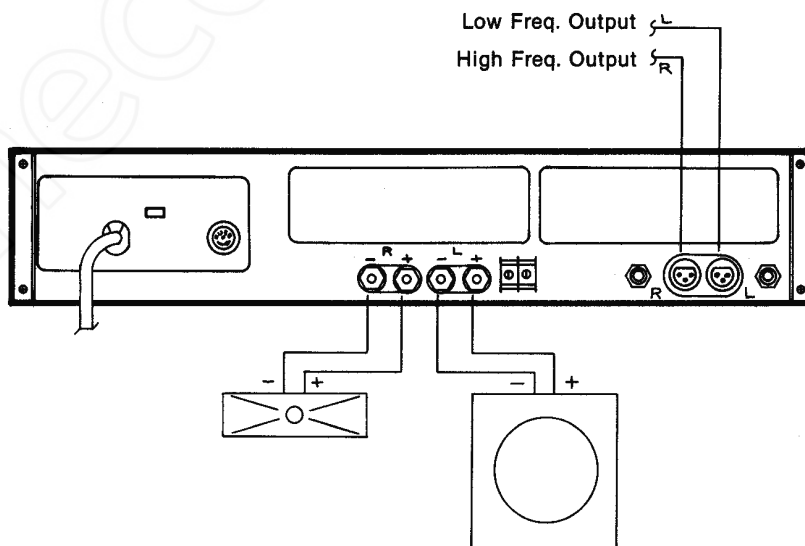

PARALLEL MONO OPERATION

The PM-2.0t may be used as a single-channel amplifier by internally re-wiring three jumpers. This change should be done **ONLY** by a qualified CARVER Service Technician or the factory. See the Appendix for the changes required.

Only the left input connectors and level control are used in the parallel mono-mode.

For two speaker mono-operation, use speakers rated at four ohms or greater. By connecting the two red terminals together, the PM-2.0t can drive a single load of two ohms impedance or greater. If the amplifier is used to drive a single speaker, the red left and right binding posts must be wired in parallel. Figure 4.

FIGURE 4

PARALLEL MONO OPERATION

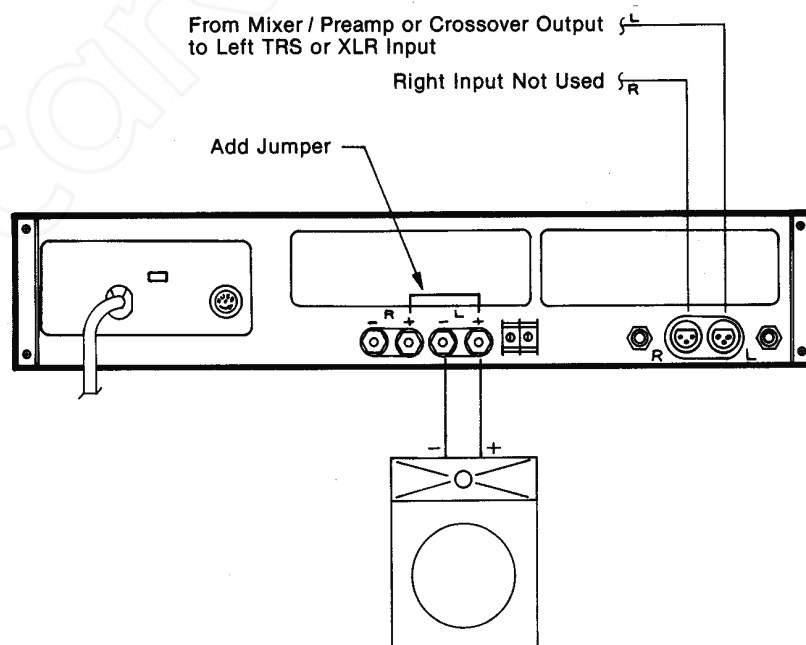

DETERMINING BALANCED OR UNBALANCED CONNECTIONS

The input connections can be either balanced or unbalanced depending on your requirements and the output capabilities of the components driving the PM-2.0t. Check your mixer/preamp or signal processing component for balanced or unbalanced outputs. Selecting a mode depends on where and how the system is installed and operated. Running a balanced system reduces noise and rejects interference especially when long cable runs are used between the mixing console and the amplifier.

If you plan to operate a balanced system, make sure all components are balanced ie. balanced outputs from the console going to the balanced inputs on an equalizer or crossover going to the balanced inputs on the PM-2.0t. If other amps are being supplied signal via the paralleled input connectors on the PM-2.0t, these connections must also be balanced. The same is true for unbalanced mode. KEEP YOUR CONNECTIONS EITHER ALL BALANCED OR ALL UNBALANCED. A mix of balanced and unbalanced can cause severe noise, hum or possible damage to the output circuitry on some balanced-drive, low-level components.

NOTE: The majority of system problems originate with improperly wired or faulty cables.

Make connections to and from the PM-2.0t with all components in the system switched OFF including the PM-2.0t. Leave all line cords unplugged.

BALANCED LINE

Selecting which input connectors to use for drive signals depends on:

- 1) the output connectors on the component supplying signal.
- 2) the type of connectors used as terminations on the stage box of a multi-paired snake cable.

The pin configurations for the PM-2.0t's input connectors are:

1. Female XLR Inputs: the connectors are wired so that Pin 1 is ground, Pin 2 is (-) Low, Pin 3 is (+) High. Figure 5.

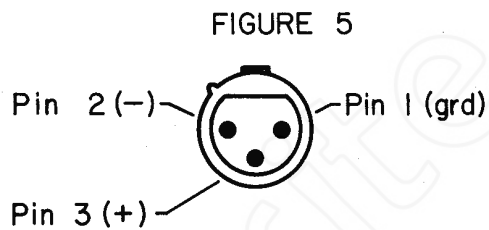

2. 1/4 inch TRS (Tip, Ring, Sleeve Inputs): These jacks are wired so that the Tip is (+) High, Ring is (-) Low, and the Sleeve is ground. Figure 6.

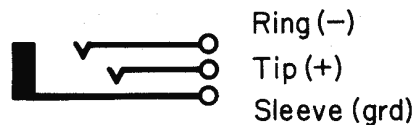

FIGURE 6

Balanced line configurations should always be made in-phase. Examples:

Pin 1 on the PM-2.0t's female XLR input corresponds to Pin 1 on a male XLR connector at the output of the component supplying drive signal.

Since the PM-2.0t's XLR and TRS input connectors are wired in parallel, the unused left and right input connectors can supply signals when cascading several amplifiers with the same drive signal. However, the patch cords must be wired in balanced mode.

UNBALANCED LINE

1. Female XLR-type Inputs: The cables supplying unbalanced drive signals are wired so the (+) is connected to Pin 3 and the ground to Pins 1 and 2. Figure 7.

FIGURE 7

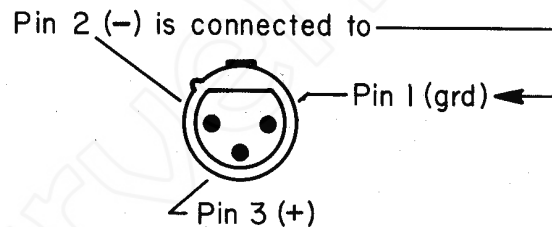

NOTE: Failure to connect Pins 1 and 2 will result in an approximate 50% reduction in gain.

2. 1/4-inch TRS (Tip, Ring, Sleeve) Inputs: The TRS 1/4" phone plugs are wired so that the tip is (+) and the ring and sleeve are wired to ground. When using standard (mono) 1/4" phone plugs, the ring and sleeve are automatically connected to ground. Figure 8.

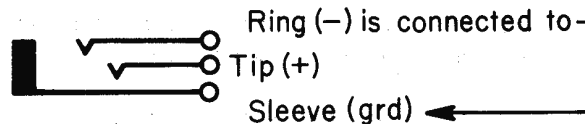

FIGURE 8

NOTE: Failure to connect ring and sleeve will result in an approximate 50% reduction in gain.

The preferred method of cascading amplifiers in the unbalanced mode is made by supplying the main drive signal to the XLR connectors. Use the standard (mono) 1/4" phone plugs to connect the other amplifiers.

SPEAKER WIRE

Use high quality speaker wire to connect the output terminals to the loudspeakers. While speaker wires as light as 16-gauge can be used to connect the amplifier to the loudspeakers, heavier-gauged speaker wires should be used in wire runs over long distances. Heavier speaker wires minimize line losses and will improve the system damping factor.

The type of speaker wire connection depends on your system's application. For mobile sound systems, dual-banana plugs are a safe and convenient method of terminating speaker wires at the amplifier and loudspeakers. Dual-banana plugs have a locator tab along one side which denotes the ground (-) side of the terminals and speaker wire. For permanent installations, tinned leads or spade lugs provide excellent terminations.

Speaker wires may be purchased with the proper terminations and wire gauge for your amplifier and loudspeakers. If you are not sure how to put a good cable system together, consult your Carver Professional Products Dealer.

4. [] INITIAL POWER UP

WARNING: IMPROPER POWER UP PROCEDURES MAY CAUSE DAMAGE TO POWER SWITCH.

BE sure Power switch is OFF. Plug the PM-2.0t into a 120 VAC outlet.

Leave the Power Switch in the OFF position for approximately 60 seconds. This allows the input DC supply to charge up, which reduces large in-rush currents and possible damage to the Power Switch.

The Power Switch may be turned ON after approximately one minute.

NOTE: This start-up procedure applies only when the PM-2.0t is first out of the box OR when the the PM-2.0t is unplugged for more than a day.

5. [] FILL OUT AND MAIL WARRANTY CARD

OPERATION

Do not operate the PM-2.0t into nominal loudspeaker impedances less than 4 ohms in dual channel operation, 2 ohms nominal loudspeaker impedances in parallel mono-mode.

POWER UP

BE SURE TO FOLLOW INITIAL POWER UP INSTRUCTIONS.

Reduce master gain controls on the instrument preamp or mixing console. Turn ON all low-level components in the sound system. This includes mixing consoles, and other related equipment.

Turn ON the PM-2.0t and other amplifiers. When the red Power LED comes ON, a start sequence of approximately 15 seconds occurs before the amplifier is ready for operation. The green Ready LEDs will light and the cooling fans will be running when the PM-2.0t is operational.

POWER DOWN

Reduce master gain control levels at the preamp or console. Turn OFF the PM-2.0t and other amplifiers. Wait for their power supplies to discharge. Turn OFF the low-level equipment.

POWER INTERRUPTION

If a power interruption occurs, the PM-2.0t will safely re-start without having to readjust the gain or mixer controls.

The inputs are muted during the re-start sequence. This normally takes approximately 15 seconds.

PROTECTION SYSTEMS

Several protective circuits have been built-in to guard against major faults that could damage the amplifier or the loudspeakers.

If any of the following fault conditions occur, the power supply will shut down and the green Ready LEDs will go out as long as the fault condition exists. The amplifier will go into a re-start mode followed by system shut down until the fault condition is corrected.

Short circuit: If a short circuit condition exists across either the left or right output binding posts, the inputs are muted and the power supply will shut down. This prevents the amplifier from driving into a short circuit condition. The amplifier will go through a re-start cycle and resume normal operation when the fault is removed.

Excessive High-frequency signals (non-musical): The protection circuits have been designed to react only to signals and oscillations that are different than any conceivable program material. Generally, excessive high frequency feedback and preamp/mixer problems will activate these circuits.

DC Offset: Significant DC offset (2-4V DC) present at the outputs.

Internal, Low-level Supply Fault: Internal component problem causing imbalance in the amplifier's low-level power supplies.

Amplifier Overheated: Shutdown is activated when the heatsink temperature exceeds 100 degrees C.

Depending on the fault condition or problem that activates the PM-2.0t's protection circuits, the amplifier will go through a re-start cycle until the problem is corrected.

MAINTENANCE

Cleaning your Amplifier

Use a soft, dry cloth to wipe the front panel and chassis. For stubborn stains use a mild detergent sparingly on a soft cloth. Do not use ammonia, alcohol or other strong solvents.

Cleaning your Fan Filter

Clean the filter as need. Remove the filter from the rear of the chassis. Shake out loose dirt and smoke buildup. If the buildup is heavy, use compressed air to clean the filter. Do NOT use ammonia or other strong solvents to clean the fan filter. To replace the filters, tuck the filter pad between the amplifier chassis and the heatsink fins.

TROUBLESHOOTING

Most problems can be traced to faulty interconnect cables and cords. Check each cable and cord with a good cable tester. Replace any faulty cables before continuing with Troubleshooting.

PROBLEM

Red Power LED off at
Power Up

SOLUTION

Check fuse and replace if necessary. If the fuse is O.K. then: Check AC line cord connection and power switches on outlet strip or power block.

Green Ready Lights come on; amplifier functions normally, then shuts down for several minutes.

Amplifier may be overheating. Check for adequate ventilation. Clean air filters, turn fan switch to high. Make sure there is no high frequency oscill-

<p>Green Ready LED light on a continuous cycle On and Off.</p>	<p>ation problem which would activate the shut down circuitry.</p>
<p>Green LED light up but no output</p>	<p>This is an indication of a fault condition. Check speaker output terminal for short circuit. If this doesn't correct the situation, see your CARVER Service Technician.</p>
<p>Green LED lit but unit will not operate in stereo mode</p>	<p>Make sure input Level controls are turned up sufficiently to pass a signal. Check preamp or mixing console for proper operation. Check input connectors.</p>
<p>Amplifier gets wet</p>	<p>Make sure the internal jumpers are set for stereo operation.</p>
<p>Noise or hum</p>	<p>Allow amplifier to thoroughly dry out before attempting to operate. If amplifier fails to operate properly after drying out, have it checked by a qualified service technician.</p>
	<p>Certain sensitive low-level components might pick up noise or hum from the PM-2.0t or other power amplifiers.</p>

If this occurs, separate the components and amplifiers until noise stops. Another option is to install a heavy shielding plate between the components for the same results. If the amplifier is being driven in a BALANCED configuration, then the ground lead may be lifted on either Pin 1 of the XLR plugs or the sleeve on the TRS phone plugs. This ground shield must remain connected to the output of the driving equipment.

One channel dead

Check dead channel input cables. Inspect all connections to be sure of a firm fit in their respective jacks at the amplifier inputs and the outputs of the preamp/mixer. Check the speaker leads at the amplifier's output binding posts to ensure proper connection. If used, inspect the loudspeaker fuses.

Lack of bass

Check speaker wires for proper phasing.

Main fuse blows

Replace ONLY with same type and rating. Using a larger fuse or fuse bypass can result in

serious amplifier damage and will void the warranty.

Continuous high power operation or running the Amplifier beyond its rated capacity. may cause the fuse to blow. To replace fuse:

- 1) SWITCH POWER OFF
- 2) UNPLUG AMPLIFIER
- 3) REPLACE FUSE
- 4) POWERUP AMPLIFIER

If fuse IMMEDIATELY blows again, remove amplifier for servicing by a qualified Service Technician.

Overheated

If the internal heatsink temperature should go over 100 degrees C or 212 degrees F, the power supply will completely shut down until it has cooled. Check for adequate ventilation. Red power Led will remain lit.

Note: If long extension cords must be used make sure line voltage does not drop below 85 volts.

thecarversite.com

This manual is either an original scan from tech's who worked at Carver corp, donated by forum members, or both. These manuals are NOT intended for re-sale. If you purchased a 'Carver Manuals' disc on ebay or another auction site, and it has this material on it, you were ripped off!

Please report any resale of this material to us at thecarversite.com

thecarversite.com

APPENDIX

Conversion to Mono-Operation

CAUTION: The following conversion should be performed only by a qualified service technician.

For conversion to mono-operation all that is required is to change the jumpers as shown in Figure 9. With the PM-2.0t wired in the mono-mode, only the left channel input is operable. If the PM-2.0t is used to drive a single 2 ohm load the two red output binding posts must be wired in parallel.

CAUTION: If this unit is converted back to stereo operation, the two red output binding posts must NOT be connected to each other.

FIGURE 9

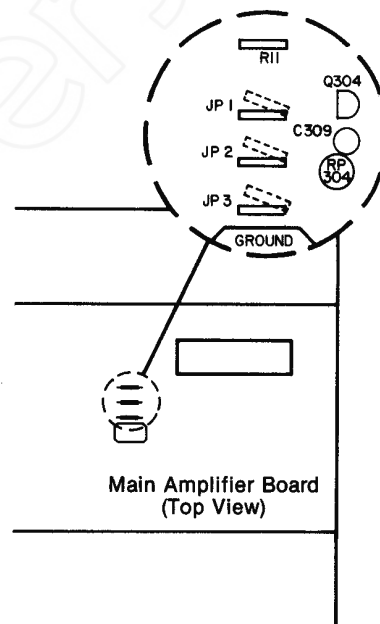

Stereo Mode: All jumpers are in parallel position.

Mono-Mode: All jumpers are in diagonal position using offset solder pads.