

thecarversite.com

This manual is either an original scan from tech's who worked at Carver corp, donated by forum members, or both. These manuals are NOT intended for re-sale. If you purchased a 'Carver Manuals' disc on ebay or another auction site, and it has this material on it, you were ripped off!

Please report any resale of this material to us at thecarversite.com

thecarversite.com

www.TheCarversite.com

CARVER

Model C-4000

Sonic Holography/Autocorrelation Preamplifier

Service Manual

CONTENTS

Introduction
Safety Information
Specifications
Test Procedure
Block Diagram
Schematics and Layouts
Parts List
Service Bulletins

CARVER Corporation

SHIP TO:

20121 48th Ave. West
Lynnwood Wa. 98036
(206) 775-6245

MAIL TO:

P.O. Box 1237
Lynnwood Wa. 98046-1237

Published by:

CARVER Corporation
20121 48th Avenue West
Lynnwood, WA 98036
(206) 775-6245

©1992 by CARVER Corporation
All Rights reserved.
Printed in the U.S.A.

No part of this publication may be reproduced, stored in a data base or retrieval system, or transmitted in any form by any means electronic, mechanical, photocopying, recording or otherwise, without the prior written permission of the CARVER Corporation.

1. INTRODUCTION

This manual is intended for use by qualified, authorized personnel only.

Due to the unique and complex circuit designs of Carver Corporation, the following procedure is recommended to diagnose & repair problems with speed and accuracy.

The best way to figure out what is wrong is to first learn what is working properly. Then, through the process of elimination, the malfunctioning circuit can be located and repaired.

The removal of parts for testing, should be kept to an absolute minimum. "In circuit" analysis should provide you with enough data to determine correct operation.

Refer to the "Design History" and "Service Bulletin" sections at the end of the service manual if you locate a part in the circuit that is not the same as the schematic. These sections will be of great assistance to you in performing a correct repair.

At Carver Corporation we continually strive for the most reliable, cost-efficient product available.

When updates and service bulletins are sent to you, please take the time to review them and insert them into the correct service manuals.

SAFETY INFORMATION

WARNING.

Any person performing the procedures described in this manual will be exposed to hazardous voltages and the risk of electric shock.

Carver Corporation assumes that any person who removes the cover from the unit has been properly trained in protecting against avoidable injury and shock.

Therefore, the procedures described here are to be performed by qualified electronics service personnel only.

We recommend that the unit be tested only when line isolation is provided by an isolation transformer. The line cord of the unit must be disconnected and the power supply fully discharged before any components are replaced. Failure to do so may result in severe damage to the unit and the risk of electric shock.

The safety tests described below must be performed properly.

CAUTION:

Before returning the unit to the customer, one of the following safety tests must be performed.

1. Check the leakage current. Connect the unit to 120 VAC supply and turn the power switch "ON". Using an ammeter, measure the current between the neutral side of the AC supply and chassis ground of the unit under test. If leakage current exceeds 0.5mA, the unit is defective.

Reverse the polarity of the AC supply and repeat.

2. Measure the resistance from either side of the linecord to chassis ground. If it is less than 500k ohms, the unit is defective.

WARNING - DO NOT return the unit to the customer if it fails one of these tests until the problem is located and corrected.

CAUTION

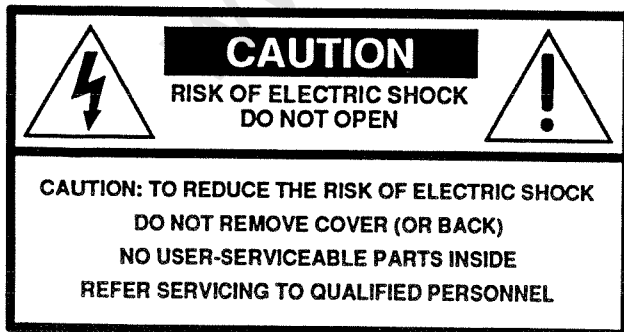

The lightning flash with arrowhead symbol within an equilateral triangle is intended to alert the user to the presence of uninsulated "dangerous voltage" within the product's enclosure, that may be of sufficient magnitude to constitute a risk of electric shock to persons.



The exclamation point within an equilateral triangle is intended to alert the user of the presence of important operating and maintenance (servicing) instructions in the literature accompanying the appliance.

2. TECHNICAL SPECIFICATIONS

The test specifications listed in this section are made in accordance with IHF-A-202, standard methods of measurement. Levels which are specified in dB are referenced to 2.5Vrms unless otherwise noted. Outputs under test are terminated at 10K ohms. Some changes in test specifications have occurred since production began, and will continue as improvements warrant. The values listed represent the worst-case conditions which the unit is warranted to maintain.

2.1 Dimensions, Assembly

The C-4000 is built in a metal case consisting of a steel chassis, steel sub-front panel and aluminum front-panel. The front panel is anodized. The unit measures:

| | |
|--------|---------|
| Width | 19 in |
| Height | 6.75 in |
| Depth | 8.50 in |

The depth does not include handles or space for connections. Although champaign-gold C-4000 units are not designed for rack mount, many post-2500 serial units have notches in the chassis behind the handles, which may be used as a template to drill the front-panel. The mounting of the headphone jack makes it necessary to remove top and bottom covers to remove the front panel for drilling. The length/breadth dimension is EIA standard. All black front-panel C-4000 units are precut for rack mounting.

2.2 Output, Gain, Load-Drive

A 250 millivolt signal at any of the high level inputs should yield 2.5 Vrms at the Main Outputs, with Volume set to full clockwise rotation and all front panel buttons out. This test condition of dB reference may vary +/-3 dB depending on the series, but will not influence frequency response or signal-to-noise ratio.

The C-4000 will clip at 6.4 Vrms output. Its Main Outputs will drive 5.1K ohm loads with no less than 5.0 Vrms at clipping, and load conditions at or above this value will not measurably affect frequency response.

The maximum gain at any high-level input is 20 dB; the Phono 1 and 2 gain to tape outputs is 40 dB at 1kHz, equalized by the RIAA characteristic.

The IC power supply is regulated to hold DC at +/-15V down to 83% of rated line voltage of 117 Vac. Output-muting clamps below 70% of rated line to prevent thumping. Load-drive specification valid to regulator threshold, 80% line.

A load impedance no lower than 4 ohms is recommended for each channel of the Time Delay power amplifier. Since Left and Center speaker terminals are in parallel, this means that speakers rated below 8 ohms may be used, but only two (Left and Right) may be connected. If a third speaker is used, all speakers must be 8 ohms minimum.

2.3 Control Functions

The preamplifier Volume control tracking error is no greater than 1dB from full-clockwise to -40dB of attenuation, and 2.5dB from -40dB to -infinity. The Volume control will attenuate the Main Outputs at full counter-clockwise, such that a 250 mVrms input at 2kHz will be limited to no more than 500 uVrms. This remaining output will vary in level with rotation of the Peak Unlimit and Correlation Manual Threshold controls, and will be minimized at their full counter-clockwise positions.

The balance control is designed to vary the level of each channel at the preamplifier's Main Outputs.

The Tone Controls are asymmetrical in boost and cut. Boost is limited to a maximum of 15 dB, while cut does not exceed 5 dB. The following boost and cut specifications are accurate to within 1 dB. The left-right mistracking of the tone controls at the fixed detents is also no more than 1dB.

| | | <u>IN</u> | <u>Turnover</u> | <u>OUT</u> |
|-----------------|--------------|-----------|-----------------|------------|
| Bass - 100 Hz | - Full boost | + 13 dB | | + 10 dB |
| | - Full cut | - 5 dB | | - 5 dB |
| Treble - 10k Hz | - Full boost | + 8 dB | | + 6 dB |
| | Full cut | - 5 dB | | - 5 dB |

The turnover switches (labeled "50 Hz/Loudness" and "8kHz/2kHz") will increase the boost of the tone controls, but will not affect the cut more than 1 dB.

The frequency response of the line amplifier is flat within 1 dB from 20 Hz to 20kHz. When the "-3 dB Trim" control is depressed, line amp gain is reduced -3 dB at all frequencies below 800 Hz, and reduced less than -0.5 dB at all frequencies above 4kHz.

The "output -15 dB" switch will reduce the output level at only the Main Outputs by -17.5 dB at all frequencies, within 1 dB.

Stereo separation between input channels of one program source is better than 55dB at 2kHz with one channel shorted. Crosstalk or bleedthrough between program sources is better than 85dB at 2kHz with all undriven inputs shorted.

2.4 Phono Amplifiers

(P/N 601-00004-00: Phono 1 and Phono 2 identical)

The RIAA response of both channels of both phono sections is accurate to within 1 dB of the standard response, from 20 Hz to 20kHz. Phono section noise is less than 80dB below a 0dB reference obtained at Tape Outputs with a 10 mVrms input at 1kHz to Phono inputs, IHF "A"-weighted.

Input overload level in the phono stages is no less than 150 mVrms at 1kHz.

Phono gain to tape outputs is 30dB.

(P/N 601-00016-00: Phono 1 [MM], Phono 2 [MC])

Phono 1 noise is less than 81dB below an input reference of 5mVrms at 1kHz, IHF A-weighted.

Phono 2 noise is less than 75dB below an input reference of 0.5mVrms at 1kHz, IHF A-weighted.

Phono 2 shall exhibit no more than 150 mVdc of offset at the Main Outputs with Volume at full clockwise.

Input overload level in the Phono 1 stage is no less than 100 mVrms at 1kHz.

Input overload level in the Phono 2 stage is no less than 5 mVrms at 1kHz.

Phono 1 (MM) gain to tape outputs is 35dB.

Phono 2 (MC) gain to tape outputs is 60dB.

2.5 Sonic Hologram Generator

No more than 1 dB of channel imbalance is introduced by the Sonic Hologram at all frequencies 4kHz and below, both input channels driven and balanced within 0.5 dB. No more than 2 dB of imbalance is introduced above 4kHz under the same conditions.

The straight-feed and cross-feed EQ levels do not deviate more than 2 dB from the test specifications outlined in "Test Procedures", step 13.

2.6 Peak Unlimiter

The Peak Unlimiter introduces no more than 1 dB of channel imbalance or insertion gain at all frequencies 30 Hz-20kHz.

Total dynamic range recovery is no less than 4.5 dB, measured as the difference between output level with PK Unlimit control at the extremes of its rotation.

Attack and release times of the level detectors which control the signal gain are fixed to provide an adequately fast attack rate to track peak transients, while maintaining a slow attack rate to unity gain to prevent tracking of impulse-noise at low levels.

The Peak Unlimiter does not exhibit DC offset when level changes take place.

2.7 Autocorrelator

The Autocorrelator introduces no more than 1 dB of channel imbalance or insertion gain at all frequencies 20 Hz-20kHz, with filter gates fully opened, fully closed, or in any intermediate condition.

Noise reduction, measured as signal attenuation in both channels with the Manual Threshold control selected and set at full counter-clockwise, is less than 0.5 dB at 800 Hz, and follows these characteristics:

| | | | |
|------|--------|-------|------|
| 2kHz | 5 dB | 10kHz | 8 dB |
| 4kHz | 6 dB | 20kHz | 8 dB |
| 7kHz | 7.5 dB | | |

With the LF Cal set fully counter-clockwise, the low frequency noise reduction, measured as signal attenuation, is 7 dB at 100 Hz, and less than 0.5 dB at 800 Hz.

Control filter ripple-induced distortion, measured as output level of channel with shorted input while other channel is driven -50 dB below output reference at 2kHz, is less than 0.8 mVrms. Filter ripple will decrease to a nominal level of 0.3 mVrms at normal Manual Threshold settings below 2:00 and in the Automatic Mode.

Time-constants of filter gate switching allow the low-frequency gate to open within 300 μ S while closing it no faster than 50 ms. High frequency gates open in less than 200 μ S. The 2kHz and 4kHz gates close no sooner than 40 ms; 7kHz, 10kHz and 20kHz gates close within 300 μ S.

The Automatic Threshold fixes 2kHz gate threshold at -55dB below output reference.

2.8 Infrasonic Filter

The Infrasonic Filter introduces no more than 1 dB of channel imbalance or insertion gain at all frequencies 20 Hz to 20kHz.

Filter rolloff is 8 dB per octave. The Infrasonic Filter is AC coupled.

Filter frequency response is within 1 dB, 20 Hz and above. Frequency response is down -3 dB at 15 Hz, -8.5 dB at 10 Hz.

2.9 Time Delay

The Time Delay between any input and the Time Delay Speaker Terminals or Low Level Outputs is within 5 ms of 35 ms or 50 ms in all post 2000 serial units. Many pre-2000 serial units are set for 50 ms and 80 ms. A minimum of 10 ms difference between the two delay length switch positions is allowed.

The recirculation buffer provides a minimum of 150 ms of sustain at the full clockwise setting of the Echo Density control. The time delay does not exhibit regenerative feedback at any Echo Density setting below 3:00.

The gain tracking of the compander noise reduction around the CCD chip is within 3dB of Main Output level at any level from 1 Vrms at Low Level Time Delay outputs to -40 dB below that reference. The frequency response compensation for headshadow maintains that the 7kHz output level be no less than -1 dB below the 2kHz output level when measured below the compander threshold, 4 to 7 dB above the residual noise floor of the delay.

The Power Amplifiers are rated at 18 watts per channel, both channels driven at 2kHz into 8 ohm loads, at no more than 0.25% THD. This distortion level does not include nonlinearities introduced by the line-level delay.

2.10 Headphone Amplifier

Power output is no less than 2.2 Vrms into 160 ohm loads for distortion levels below 0.05% THD. Frequency response is within 1 dB, 20 Hz to 20kHz.

2.11 Noise, Distortion

Phono noise specifications are found in section 2.4. High-level and processor noise is no less than -74 dB below output of 2.0 Vrms, with all high-level processors switched into the signal path simultaneously.

Volume-up noise, with selected high-level inputs shorted, is less than (IHF "A"-weighted):

| | | |
|-------------------|--------|---------------|
| Line amp | -85 dB | |
| Hologram In | -83 dB | |
| PK Unlimit In | -76 dB | |
| Autocorrelator In | -80 dB | |
| Infrasonic In | -80 dB | |
| Tone In | -85 dB | controls flat |

below 2.0 Vrms at Main Outputs. The delay-length switch must be depressed, to eliminate ultrasonic clock noise if IHF "A" filter is not used.

Volume-down noise is not affected by Peak Unlimiter, Autocorrelator or Infrasonic Filter, and is less than (IHF "A"):

| | |
|----------|--------|
| Line amp | -88 dB |
| Tone amp | -88 dB |
| Hologram | -83 dB |

below 2.0 Vrms at Main Outputs.

Time Delay noise is specified with any high level input selected and shorted, Time Delay Output Level and volume at full clockwise, all high level processors switched out, delay length at 50 mS. A maximum of 2.75 mVrms at Main Outputs is allowed. The 60 Hz hum component and its harmonics may constitute no more than 25% of this voltage.

Distortion in the line amp and high-level processor circuits is affected by the settings of the Peak Unlimit and Correlator Threshold settings when input levels exceed that sufficient to yield 1 Vrms at Main Outputs with volume at full clockwise. The lower settings of these threshold controls will yield lower distortion. Total Harmonic Distortion, as measured by the Sound Technology 1700A, is less than 0.05%, 20 Hz to 20kHz, at rated output of 2.5 Vrms output. Typical distortion levels at typical settings of the threshold controls is 0.02% THD.

The line amp is not restricted by slow-induced distortion at any level within the audio passband up to 20kHz.

SMPTE intermodulation distortion, 60 Hz and 7kHz mixed at 4:1, is no more than 0.05%, at rated output or lower.

C-4000 TEST PROCEDURE

Equipment needed:

Dual Trace Oscilloscope
Two AC Voltmeters
Signal Generator, 10 Hz - 20kHz,
10 dB step attenuator
8 ohm Load Resistor
AC variac fused no lower than 1.5A

Summary of Test:

1. Energizing
2. High Level Signal Routing
3. Dethump
4. Volume Tracking
5. Phono 1 and 2
6. Stereo/Mono and Separation
7. Tone Controls
8. -3 dB Trim Below 800 Hz
9. Output -15 dB
10. Speaker Off
11. Infrasonic Filter
12. Balance
13. Sonic Hologram Generator
 - Type I vs. Type II
 - Type I
 - Injection Ratio and Listening Angle
 - Mono Balance
 - EQ Straightfeed
 - EQ Crossfeed
 - Type II
 - Injection Ratio and Listening Angle
 - Mono Balance
 - EQ Straightfeed
 - EQ Crossfeed
14. Peak Unlimiter
15. Auto Correlator
 - Manual Threshold
 - Automatic Threshold
 - LF Cal
16. Time Delay
 - Line Level
 - Power Amp
17. Headphone Amplifier
18. Volume Attenuation
19. Phono Noise
20. High-Level Noise
21. Load Drive and Voltage Regulators

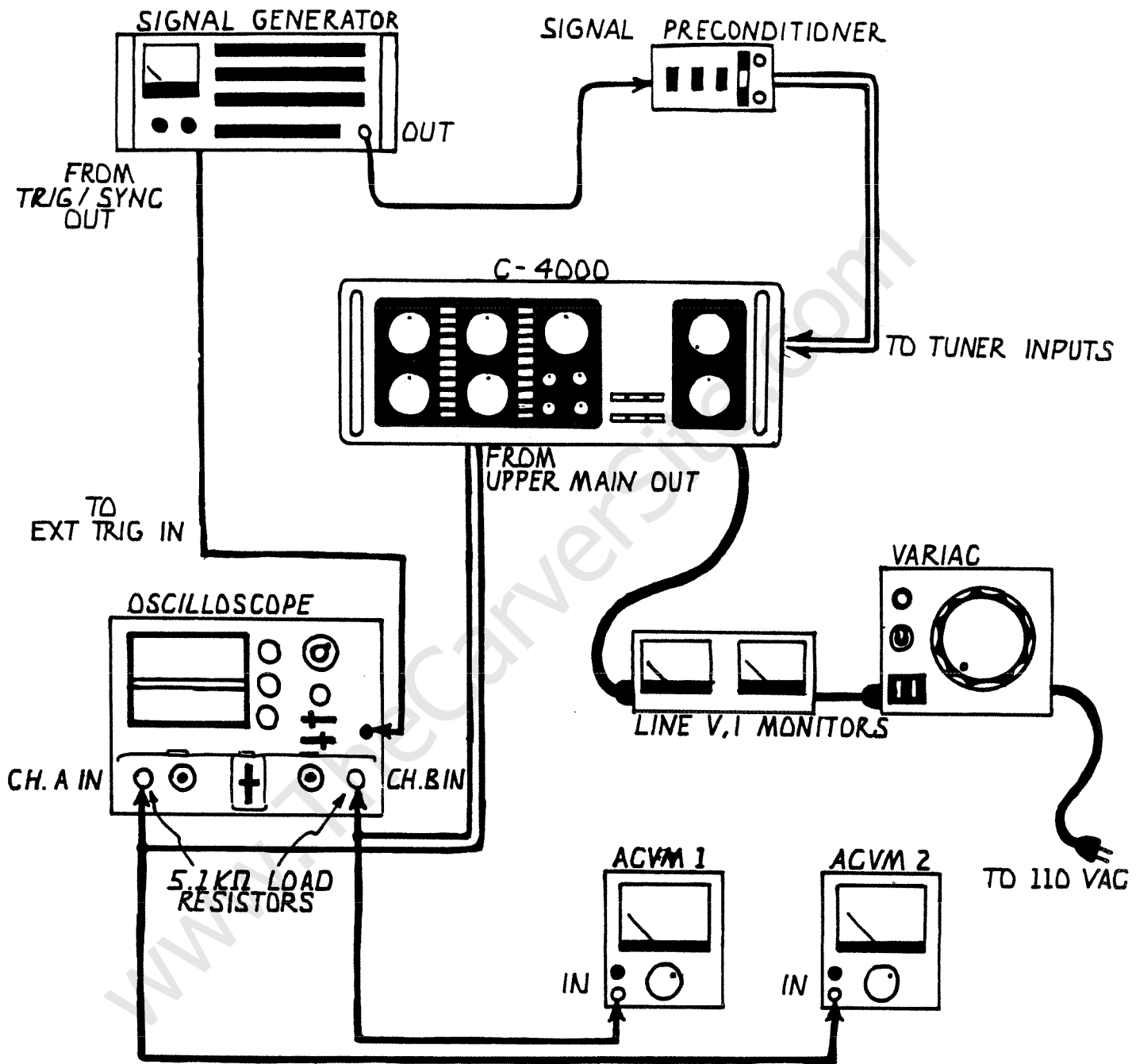

FIG. 1 - INITIAL TEST EQUIPMENT SETUP

C-4000 Test

Begin with all switches out, volume fully clockwise, balance centered.

1. Energizing - Plug AC cord into 110V AC (220V AC). Push the power switch. Verify LED next to Correlation Manual pot is on. Depress and release Correlation automatic threshold button and verify its LED lights.
2. High Level Signal Routing - Verify proper operation of all Inputs and Outputs (except Phono inputs) as shown in the table below. Drive the indicated input with 250 mV, 2kHz and monitor the indicated outputs with an oscilloscope and AC voltmeters.

| <u>Input</u> | <u>Output</u> | <u>Selector</u> | <u>Copy</u> | <u>Monitor</u> | <u>Level</u> |
|--------------------|---------------|-----------------|--------------------|--------------------|--------------|
| Tuner | Upper Main | Tuner | Out | Out | 2.5V |
| Tuner | Lower Main | Tuner | Out | Out | 2.5V |
| Aux 1 | Lower Main | Aux 1 | Out | Out | 2.5V |
| Aux 2 | Lower Main | Aux 2 | Out | Out | 2.5V |
| Tape 1 | Lower Main | Any | Out | Tape 1 | 2.5V |
| Tape 2 | Lower Main | Any | Out | Tape 2 | 2.5V |
| External Processor | Lower Main | Any | External Processor | External Processor | 2.5V |
| Tape 1 | Tape 2 | Any | 1 to 2 | Out | 175mV |
| Tape 2 | Tape 1 | Any | 2 to 1 | Out | 175mV |
| External Processor | Upper Main | Any | External Processor | External Processor | 2.5V |
| Tuner | Tape 1 | Tuner | Out | Out | 175mV |
| Tuner | Tape 2 | Tuner | Out | Out | 175mV |

3. Dethump - Drive Tuner inputs, monitor Upper Main Outputs. Obtain 2.5V out. Switch power off. Verify output is clamped -30 dB both channels during power down. Depress Power switch. Verify output is clamped -30 dB both channels for minimum 1 second before normal 2.5V output resumes.
4. Volume Tracking - Use AC voltmeters and oscilloscope to verify that the output level balance does not vary more than 1 dB from full-clockwise to -40 dB below 2.5V. Return volume control to full-clockwise.
5. Phono 1 and 2 - Test the Phono stages as follows:

| <u>Input Frequency</u> | <u>Input Level</u> | <u>Output Level at Tape 1 Out</u> |
|------------------------|--------------------|-----------------------------------|
| 20 Hz | 9.7 mV | 2.5V |
| 200 Hz | 34.5 mV | 2.5V |
| 2kHz | 125 mV | 2.5V |
| 20kHz | 870 mV | 2.5V |

The output level should be within +/-1 dB of 2.5V. This insures compliance with the RIAA recording standard. If you have an "inverse RIAA" generator or filter, it can be used to check the Phono section.

6. Stereo/Mono and Separation - Select and drive the tuner inputs with a 250 mV 2kHz signal. Unplug and short each input one at a time, and verify that one output channel is lost at the C-4000 main outputs. Leaving one channel shorted, depress the Stereo/Mono Switch, verify both outputs register at -6.5 dB. Release Stereo/Mono and verify that any signal present in the undriven channel is at least 55 dB below the driven channel.
7. Tone Controls - Select and Drive Tuner inputs as per the chart below and verify the indicated amounts of boost and cut at full clockwise (boost) and full counter clockwise (cut) rotation.

| <u>Freq.</u> | <u>Turnover SW.</u> | <u>Boost</u> | <u>Cut</u> | <u>Variance</u> |
|-------------------------|---------------------|--------------|------------|-----------------|
| <u>Treble Controls:</u> | | | | |
| 12kHz | 8kHz | +7 dB | -5 dB | 2 dB |
| 12kHz | 2kHz | +10 dB | -5 dB | 2 dB |
| <u>Bass Controls:</u> | | | | |
| 50 Hz | 40 Hz | +18 dB | -5 dB | 2 dB |
| 50 Hz | Loudness | +21 dB | -5 dB | 2 dB |

With tone controls centered there should be less than 1 dB difference in gain with the Tone switch IN or OUT.
 With tone controls at full rotation, there should be less than 2 dB of channel imbalance with Tone IN, at any setting of the turnover switches.

8. -3 dB Trim Below 800 Hz - Select and drive Tuner inputs to obtain 0 dB reference @ 2.5V, 2kHz at Main Outputs. Insertion gain should be as follows when -3 dB trim is IN:

| | | |
|---------------|-------------|--------------|
| <u>100 Hz</u> | <u>2kHz</u> | <u>15kHz</u> |
| -3.5 dB | -1.5 dB | 0 dB |

9. Output -15 dB - Select and drive Tuner inputs to obtain a 2.5V 0 dB reference at 2kHz at Main Outputs. Switch "Output -15 dB" IN and verify a drop in output of 18 dB, +/- 2 dB.
10. Speaker Off - With this switch IN, it should not be possible to obtain an output voltage at the Main Outputs.
11. Infrasonic Filter - Select and drive Tuner inputs to obtain a 2.5V 0 dB reference at 2kHz at the Main outputs. Insertion gain should be as follows when Infrasonic Filter is IN:

| | | | |
|-------------|--------------|--------------|--------------|
| <u>2kHz</u> | <u>20 Hz</u> | <u>15 Hz</u> | <u>10 Hz</u> |
| 0 dB | -0.5 dB | -3 dB | -8.5 dB |

12. Balance - Select and drive Tuner inputs to obtain a 2.5V 0 dB reference at 2kHz at Main Outputs. Center the Balance control at 12:00 and verify no more than 1 dB difference in output level between the two channels. Rotate the balance controls to the extremes of its rotation; verify that left only and right only outputs are fully attenuated.
13. Sonic Hologram Generator - Note: Check C-4000 Serial Number. If serial number is four-digit and has no letter, the unit is fitted with a Type I Hologram. If the serial number is followed by a letter "C", it is fitted with a Type II. Select the test depending on the serial number.

Type I: The function of the front and back panel hologram switches is as follows:

Injection Ratio: Varies the ratio of crossfeed injection to straight feed. The crossfeed level is a constant level below straight feed.

| | |
|---------------|--------------------|
| <u>Normal</u> | <u>Theoretical</u> |
| -5 dB | -3 dB |

Listening Angle: Varies the length of the delay in the crossfeed by 12 uS to compensate for speaker placement. To test these functions, select and drive Tuner inputs to obtain a 2.5V 0 dB reference at 2kHz at main outputs. Remove left input cable and insert shorting plug. Depress Sonic Hologram button IN. Output should be as follows:

| | | |
|-------|--------------------|-------------------------|
| | <u>Inj. Normal</u> | <u>Inj. Theoretical</u> |
| Right | -2 dB | -1 dB |
| Left | -7 dB | -4 dB |

Repeat with right input shorted, left driven. Leave right channel shorted. Drive with 10kHz input. Set scope at 10 uS per horiz. division. Switch Listening Angle between Normal and Wide and observe 10-14 uS of phase shift.

Mono Balance: Drive both selected input channels to obtain a 0 dB reference at 2.5V output at 2kHz at Main Outputs. Make certain that input levels are balanced to within 0.5dB at Main Outputs with Hologram switched OUT. Switch Hologram IN. Check for the following maximum imbalances in both positions of Inj . Ratio and Listening Angle switches:

100 Hz: 1.5 dB 2kHz: 1.5 dB 10kHz: 2 dB

Equalization of Straight-Feed: Drive each channel separately, one at a time, to obtain a 2.5V 0 dB reference at the driven Main Output with the Hologram switched OUT. Switch Hologram IN. Straight-feed EQ measures output of driven channel. Inj. Ratio set to Normal, Listening Angle set to Normal. Perform the following high freq. tests:

2kHz: -2 dB +/-1 dB
10kHz: 0 dB +/-1 dB

Reduce input level for a 0.8V reference. Adjust input level as outlined above. Perform the following low frequency tests with meters set on 3V scale, with one channel driven and Hologram IN:

10 Hz: -1.5 dB +/- 1.0 dB
100 Hz: +5 dB +/- 1.5 dB

Straight feed EQ should differ no more than 1 dB in either position of Injection Ratio at all frequencies 10kHz and below. Straight feed EQ should differ no more than 0.5 dB in either position of Listening Angle.

Equalization of Cross-Feed: Measure left channel output with right channel driven at the frequencies shown above in Straight feed EQ test. Crossfeed EQ should track straight feed EQ at 6 dB below straightfeed levels above, +/-1 dB, Injection Ratio set to Normal. Perform the following additional tests:

15kHz: -30 dB +/-1 dB
20kHz: -50 dB +/-1 dB

Type II:

Injection Ratio: Varies the relative levels of L-R to L+R signal which is delayed and cross-fed.

Listening Angle: Selects a single delay length (Normal), or a mix of three delays (Wide).

To test these functions, select and drive Tuner inputs to obtain a 0 dB reference at 2.5V at Main Outputs at 2kHz. To test Injection Ratio it will be necessary to continuously vary the input signal level of each channel separately: Reduce left channel input level with Hologram IN and Injection Ratio in Normal. As input level decreases, the output

of that channel should decrease and appear to phase-shift (lag). Repeat this test with Injection Ratio set to Theoretical. Output of channel which is being reduced in input level will appear to decrease in level and phase-lag, but will increase in level from a maximum decrease of -8 dB, up to -5 dB when input is fully attenuated. To test Listening Angle, refer to Crossfeed-EQ test, as the effect of mixing multiple delay lengths primarily effects frequency response for bench-test purposes.

Mono Balance: Drive both selected input channels to obtain a 0 dB reference at 2kHz at Main Outputs. Make certain input levels are balanced to within 0.5 dB at Main Outputs with Hologram OUT. Switch Hologram IN. Check for the following maximum imbalances in both positions of Inj. Ratio and Listening Angle switches.

100 Hz: 1.5 dB 2kHz: 1.5 dB 10kHz: 2 dB

Equalization of Straight-feed: Drive each channel separately, one at a time, to obtain a 2.5V 0 dB reference at the Main Output of the driven channel, with Hologram OUT. Switch Hologram IN. Measure the following levels:

10 Hz: -10 dB +/- 1 dB
 100 Hz: - 1 dB +/- 1 dB
 2k Hz: 0 dB +/-1.5 dB
 10k Hz: 0 dB +/-1.5 dB

Levels of straight feed should vary as follows:

Injection Ratio IN: +1 dB +/- 0.5 dB
 Listening Angle Normal/Wide: 0 dB +/- 0.5 dB

Equalization of Crossfeed: Measured as amplitude vs. frequency of left channel output with right channel driven, and right channel output with left channel driven. Measure the following levels referenced to 0 dB level of opposite channel driven with Hologram switched OUT. Switch Hologram IN and measure:

10 Hz: -1 dB +/-1 dB

Injection Ratio
OUT IN

200 Hz: -7 dB -5 dB +/-1 dB
 2kHz: -6 dB -2.5 dB +/-1 dB

20kHz: Inj. Ratio In, Listen Angle Normal: -3 dB +/-1 dB
 Inj. Ratio Out, Listen Angle Wide: -15 dB +/-2 dB

14. Peak Unlimiter - Select and drive Tuner inputs to obtain a 2.5V, 2kHz, 0 dB reference at Main Outputs. Turn the PK Unlimit control pot fully clockwise and verify that the LED adjacent to it is lit. Switch Peak Unlimiter IN and verify an increase in output level of both channels of 2 dB +/-1dB. Now rotate Pk Unlimit pot counter-clockwise until LED just goes off. Verify output level of +0.5 dB +/-1 dB. Rotate pot to full counter-clockwise. Verify decrease of -2.5 dB +/-1 dB. When the pot is then quickly rotated to full clockwise, the meter should react quickly to roughly -0.5dB, then rise slowly (2.5 seconds) to +2 dB. Total dynamic expansion should be 5.5 dB +/-1 dB.
15. Autocorrelator - Select and drive Tuner inputs with signal to obtain a 0 dB, 2.5V, 2kHz reference at Main Outputs. Switch the Automatic Threshold button OUT, set Manual Threshold at 12:00. Switch Autocorrelator IN, verify an insertion gain difference of no more than +1 dB. At each of the frequencies listed below, rotate the Manual Threshold pot to full counterclockwise, then back to 12:00. Verify the designated attenuation takes place between 7:00 and 8:00 on the pot rotation.

2kHz: -5 dB +/-1 dB
 4kHz: -6 dB +/-1 dB
 7kHz: -7.5 dB +/-1 dB
 10kHz: -8 dB +/-1 dB
 20kHz: -8 dB +/-1 dB

Reset to 2kHz. Switch Threshold to Automatic, attenuate input signal by the following dB levels, verify output decreases as indicated:

| <u>Input</u> | <u>Output</u> |
|--------------|------------------|
| -30 dB | -30 dB +/-1 dB |
| -40 dB | -41.5 dB +/-1 dB |
| -60 dB | -65 dB +/-1 dB |

Reset signal and meters to 100 Hz, 0 dB @ 2.5V out. Switch Correlator IN, set LF Cal at 12:00. Verify insertion gain of no more than +/-1 dB. Rotate LF Cal to full counterclockwise. Verify level decrease of -7 dB +/-1 dB at output. Reset LF Cal to 11:00, verify signal returns to 0 dB between 7:00 and 9:00 on control.

16. Time Delay - Refer to block-diagram, schematics, and circuit description for outline of circuit configuration. Set meters and scope for 2.5V, 0 dB, 2kHz reference level at Main Outputs, Tuner inputs driven and selected. Reduce Volume and Time Delay Output Level to full-counterclockwise. Reconnect audio cables from Main Outputs to Low Level Delay Outputs.

Line Level Delay Functions: Push Time Delay button IN. Verify signal at both outputs when Time Delay Output Level and Volume set at 12:00. Switch power off, then on 2 seconds later. Verify output is cut immediately when power is switched off, and does not come up for at least 1 second after power-on.

Mono Drive: Pull each input cable, one at a time, verify output present unless both inputs are removed or shorted.

Input Headroom: Rotate volume until delay output begins to visibly distort. This distortion should not be a sharp "clipping", but a "rounding" of the sine-wave peaks. If sharp clipping occurs, reduce Output Level, advance Volume until input overload is reached. This rounding distortion should be symmetrical on top and bottom halves of waveform, and should not occur at any volume setting below 12:00.

Delay Length: If a pulse generator is available, it can be used to measure delay length. If not, the following procedure is offered:

1. Connect one channel of scope to Main Outputs, other to Low Level Delay Outputs.
2. Adjust Volume, Output Level, and scope position controls so that each channel of the scope can be viewed separately.
3. Set scope to trigger internally off the channel connected to the Main Outputs. Set trigger to Manual/Internal.
4. Set scope to 10 mS/div (vernier at Cal). Set C-4000 Echo Density at full counterclockwise.
5. Rapidly push and release the C-4000 Tape 1 Monitor button to obtain a tone-burst display when scope trigger level is set correctly.

6. Trace of main output burst should begin at left edge of graticule. Trace of Delay output burst should begin at a fixed distance to the center of the graticule.

Remember: You must continue to push and release the Tape 1 Monitor. With the C-4000 delay-length switch in its "35mS" position (OUT), the Delay output trace should begin 3-4 horizontal divisions right of main output trace. Press delay length switch to "50 Hz". Delay trace should now be 4.5 to 5.5 horizontal divisions right of main trace.

Note: Due to engineering changes, be certain to contact the factory before concluding that a C-4000 is defective due to results of this test.

Recirculation: If your test-bench is already set up to do the delay-length test above, refer to test #1 below. If not, refer to test #2.

Test #1: Set scope to 20 mS/div. Rapidly press and release Tape 1 Monitor, so that both leading and trailing edges of the delay toneburst trace are visible. Rotate Echo Density to 3:00 position. Trailing edge should meet leading edge of recirculated burst, which will lead into another lower in amplitude, etc.

Test #2: Monitor Low-Level delay outputs with oscilloscope, select and drive Tuner inputs with 250 mV at 2kHz. Adjust Volume and Delay Output level controls to 12:00 position. Set delay length to 50 mS. Rotate Echo Density to full clockwise. Push Tape 1 Monitor. Output should decay slowly, sustaining a minimum of 20 mS. If output goes into regenerative feedback with Echo Density at full clockwise, reduce to 3:00 - regenerative feedback or "runaway" should not occur.

Gain Tracking: Connect one channel of scope/meter monitor system to either channel of Main Outputs, other to either channel of Low Level Delay Outputs. Adjust Volume and Time Delay Output Level to obtain 0.8V "0 dB" reference from both Main and Delay, with C-4000 Tuner inputs driven with 250 mV and selected. It may be necessary to overdrive the input of the delay slightly, indicated by visible distortion of sine waveform: this is normal. Attenuate the input level from the signal generator in 10 dB steps while upranging both meters by 10 dB steps. Main output will track as closely as the generator's step-attenuator. Delay output should track within +/-3 dB from 0 dB (0.8V out) to -40 dB.

Frequency Response: Select and drive Tuner inputs, adjust input level to obtain 2.5V, 2kHz, 0 dB reference at Main outputs. Reconnect scope and meters to Low Level Delay outputs. Set Volume and Delay Output Level to 12:00. Switch Time Delay IN. Set Echo Density fully counter-clockwise. Delay Length IN to 50 mS. Reduce volume to full attenuation. Uprange scope to sufficient vertical gain to look at residual signal and noise. Bring Volume up, observe trace for action of compander (slight offset when Volume is varied). Set Volume for output level about 5 dB lower than the low-signal threshold of the compander indicated by no DC "bounce" when Volume is varied. Note reading on meters. Switch generator to 7kHz. Frequency response should be from -1 to -5 dB below 2kHz level.

Phase Response: Output sinewaves from left and right delay outputs should exhibit the following phase relationships:

20 Hz less than 5 degrees.

4 Hz 180° +/-10 degrees.

This observation can be made at all levels.

Delay Power Amp - The output of the power amplifiers is fed through a divider to the Low Level Delay Outputs, so scope and meters may remain connected here.

Output Power: Select and drive any high-level input with a 2kHz signal, monitor Low Level delay outputs with meters and scope. Set Volume at 12:00, adjust Time Delay Output level of not less than 1.2 volts. Sequentially load the Left, Center, and Right speaker terminals while measuring output voltage at clipping. Verify not less than 1.0 volt.

Bias: Set Time Delay Output level at 12:00, Delay IN, 50 mS, Echo Density at minimum, uprange scope vertical gain to display output with Volume set no higher than 8:00. Sequentially load Left and Right speaker terminals, and observe crossover point of output waveform for notch, or visible "gap" in waveform when loaded.

Limiters: If current limiters are operating correctly, the Time Delay speaker terminals can be directly shorted without damage to power amplifier. Monitor Low Level Delay outputs, set Volume and Time Delay Output Level at 12:00. Select and drive a high-level input with 2kHz, 250 mV. Push Time Delay IN. Set volume fully counter-clockwise. Use a tool to short Left and Right Time Delay Speaker Terminals. Increase Volume to 12:00, while watching for any evidence that current is being drawn from the AC line. If current-limiters are working, the fuse will not blow, and normal output will resume when short is removed.

17. Headphone Amplifier - Select and drive Tuner input with 2kHz signal. Monitor output of headphone amplifier by inserting a dummy plug into front panel jack. Set C-4000 volume at full clockwise. Attach two 160 ohm load resistors (.25W) across outputs. Verify no less than 2.2 Volts at clipping.
18. Volume Pot Attenuation - With selected high-level input driven with 250 mV, 2kHz, switch all front-panel switches out, rotate Volume fully counter-clockwise. Monitor Main Outputs with scope and meters set to observe and measure residual signal. Observe slight "square" glitches, but no sine-shaped signal. Output should not exceed 500 mV. Rotate Correlation Manual Threshold and PK Unlimit pots fully clockwise.
19. Phono Noise - Drive Phono 1 inputs with a 10 mV signal at 2kHz and obtain a 0 dB reference with a pair of AC voltmeters connected to Tape 1 outputs. Set selector to Phono 1, all front-panel switches out. Remove the inputs and insert shorting plugs. Verify that residual noise level is at least -80 dB below the 0 dB reference (IHF "A" weighted). Repeat this test for Phono 2, verifying in addition no more than 150 mV of offset on Phono 2.
20. High-level Noise - Select and drive any high-level input with a 2kHz signal to obtain a 2 volt output at the Main outputs with a pair of AC voltmeters. Remove inputs and insert shorting plugs. Verify that with all Volume settings any output is at least -85 dB below the 2 volt reference. With Volume at full-clockwise, depress, in sequence, Tone, Infra-sonic Filter, Sonic Hologram, Peak Unlimiter and Auto Correlator. Output should remain at least -74 dB with any one of these IN.
21. Load-Drive and Voltage Regulators - Select and drive any high level input with a 1kHz signal adequate to clip the line amp.

With volume at full-clockwise, monitor Main Outputs with scope and meters. Attach two 5.1k ohm, .25 watt resistors across Main Outputs and verify:

- 1) No more than 1 dB of imbalance at 20 Hz, 2kHz, 20kHz.
- 2) No less than 5.0 Volts at clipping.
- 3) Vary line voltage with variac to 75% of line. No variation in height of rails (clipping level) should be evident down to 80% of line voltage.

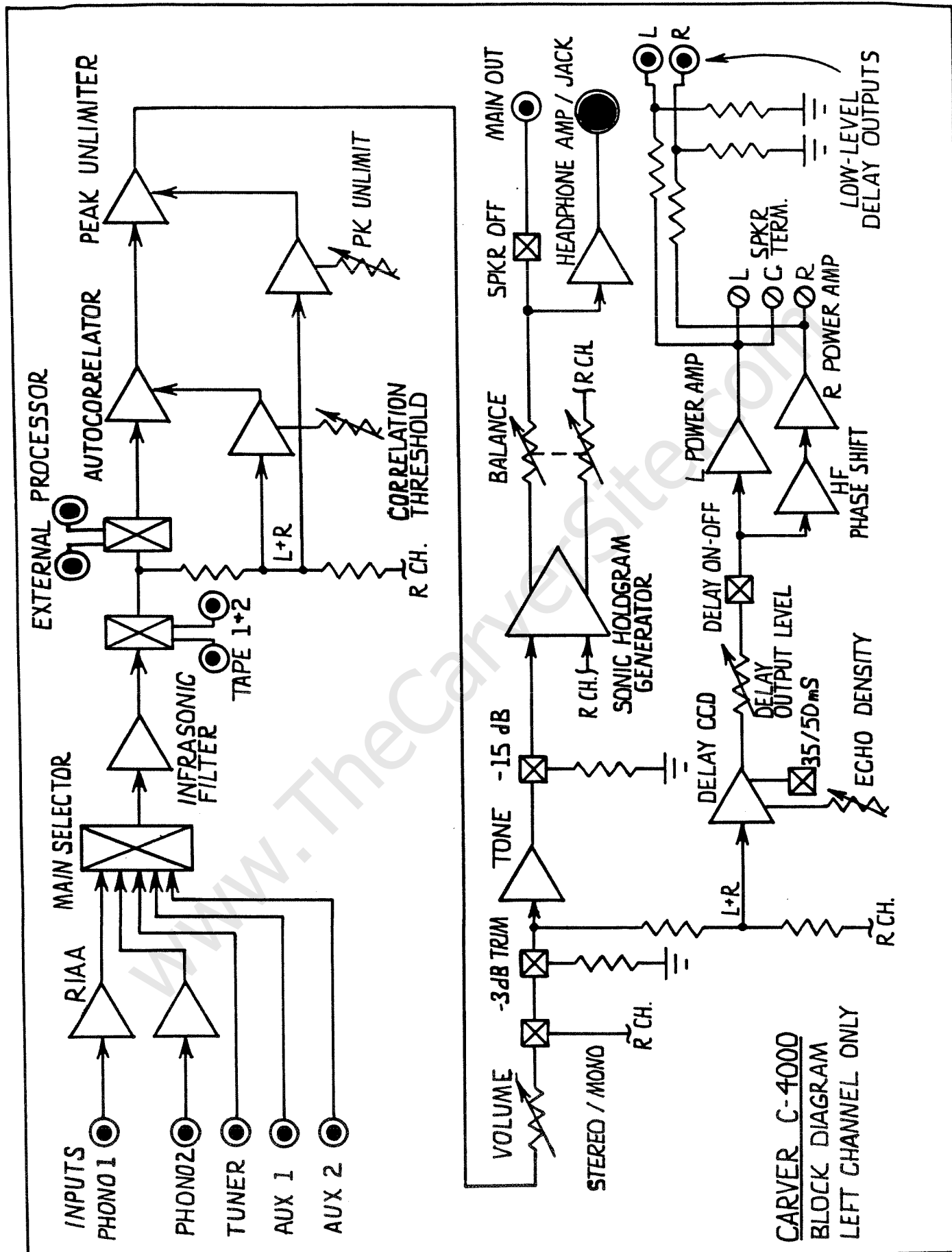

CARVER C-4000
BLOCK DIAGRAM
LEFT CHANNEL ONLY

C-4000 SIGNAL FLOW

Refer to Block Diagram on Page 24 and Schematics.

1. Phono 1 and 2 equalized by RIAA op-amps.
2. Phono 1 and 2, Tuner, Aux 1 and 2 inputs selected by Main Selector Switch.
3. Infrasonic Filter after Selector.
4. Tape Monitor and Dub after Infrasonic Filter.
5. Autocorrelator and Peak Unlimiter control lines taken after tape switching.
6. External Processor Loop after control lines.

-All Above on Phono Board-

7. Signal off Phono, onto Mother board at pins 5 and 6.
8. Signal to Correlator switch via Switch Board pins 13 and 14, and to Correlator via pins 15 and 2.
9. Signal to Peak Unlimiter switch from Correlator pins 1 and 14 and from Correlator switch via Switch Board. Peak Unlimiter input at Peak Card pins 2 and 4. Output pins 5 and 6.
10. Signal to Volume Pot via Amp Card Pins 1 and 2.
11. Signal from Volume Pot via Amp Card pins 14 and 15 to Tone Amp Card pins 14 and 15.
12. Signal from Tone Card outputs, pins 13 and 12, to Hologram switch and to Hologram Card pins 1 and 2.
13. Signal from Hologram Card outputs, pins 3 and 4, to Hologram switch.
14. Signal from Hologram switch to:
 - "Dethump" FET's on Motherboard.
 - Balance pot via Amp Card via pins 9 and 10.
 - Headphone Amp, Headphone Jack.
 - Speaker-off switch on Tone Card via pins 9 and 10.From Speaker-off switch via pins 8 and 11 to Phono Card pins 9 and 10, to Main outputs on Phono Card.

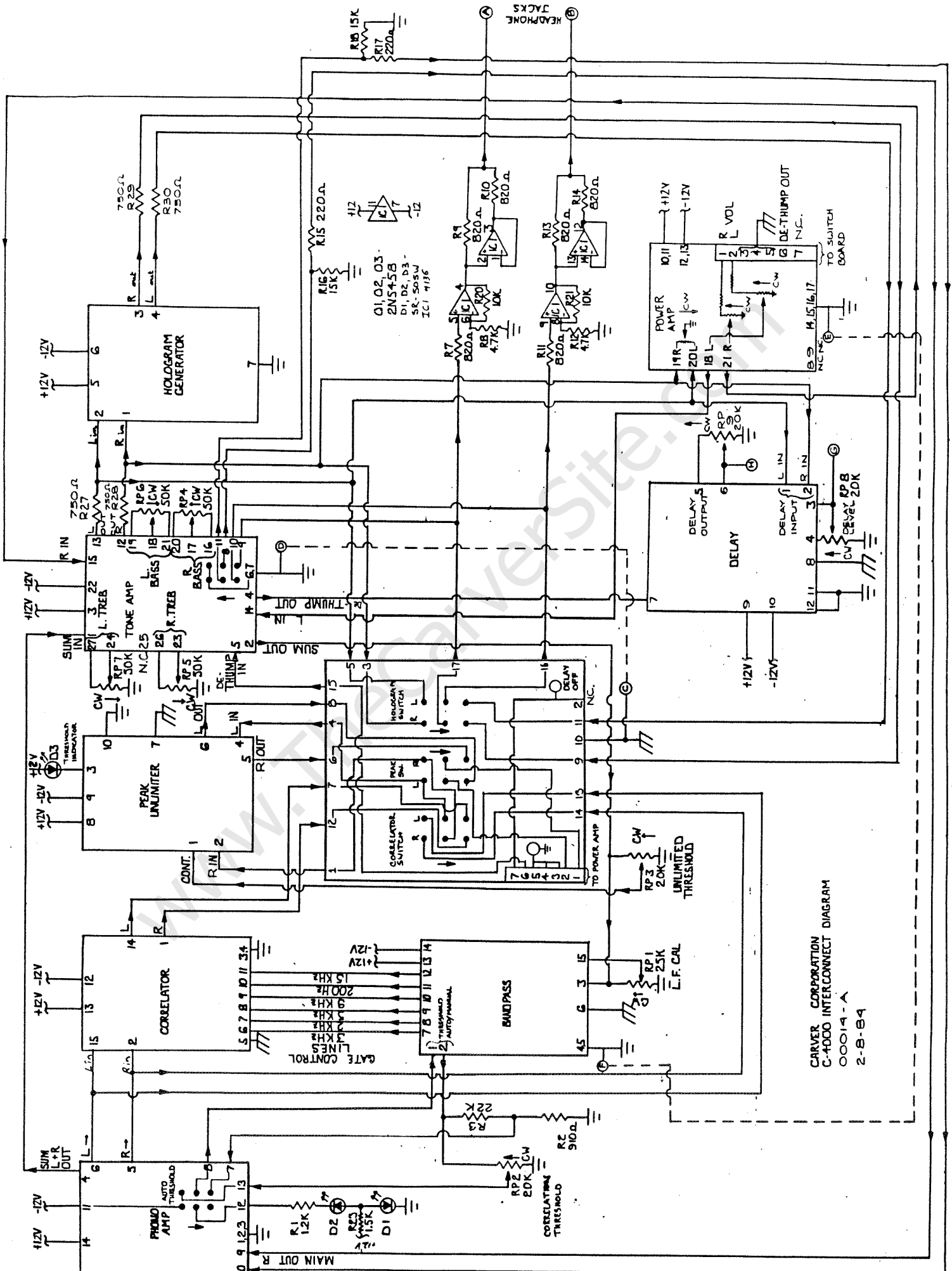

CARVER CORPORATION
 C-4000 INTERCONNECT DIAGRAM
 00014-A
 2-B-64

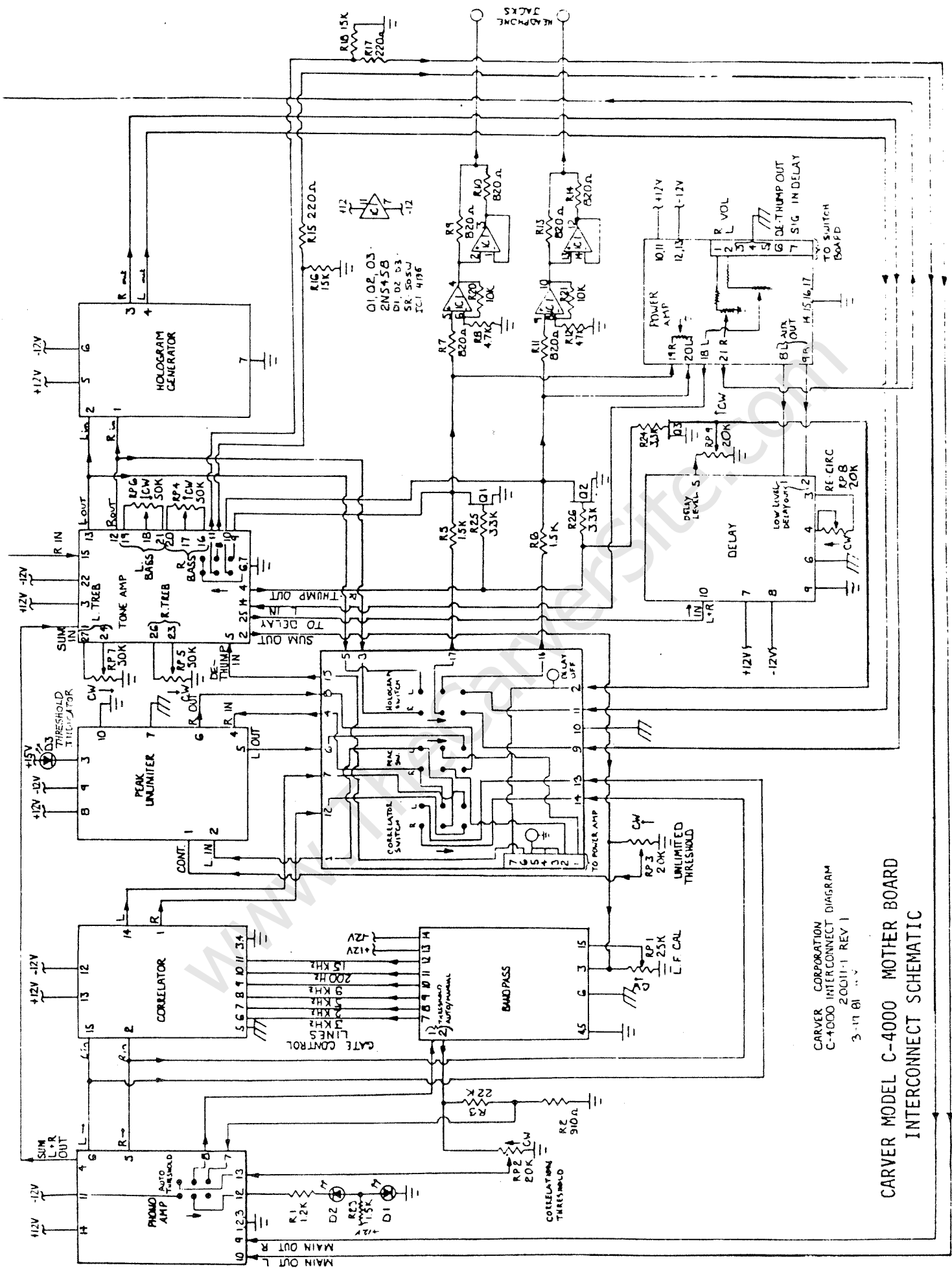

CARVER CORPORATION
 C-4000 INTERCONNECT DIAGRAM
 20011-1 REV 1
 3-17-81

CARVER MODEL C-4000 MOTHER BOARD
 INTERCONNECT SCHEMATIC

CARVER MODEL C-4000
MOTHER BOARD Parts Locator

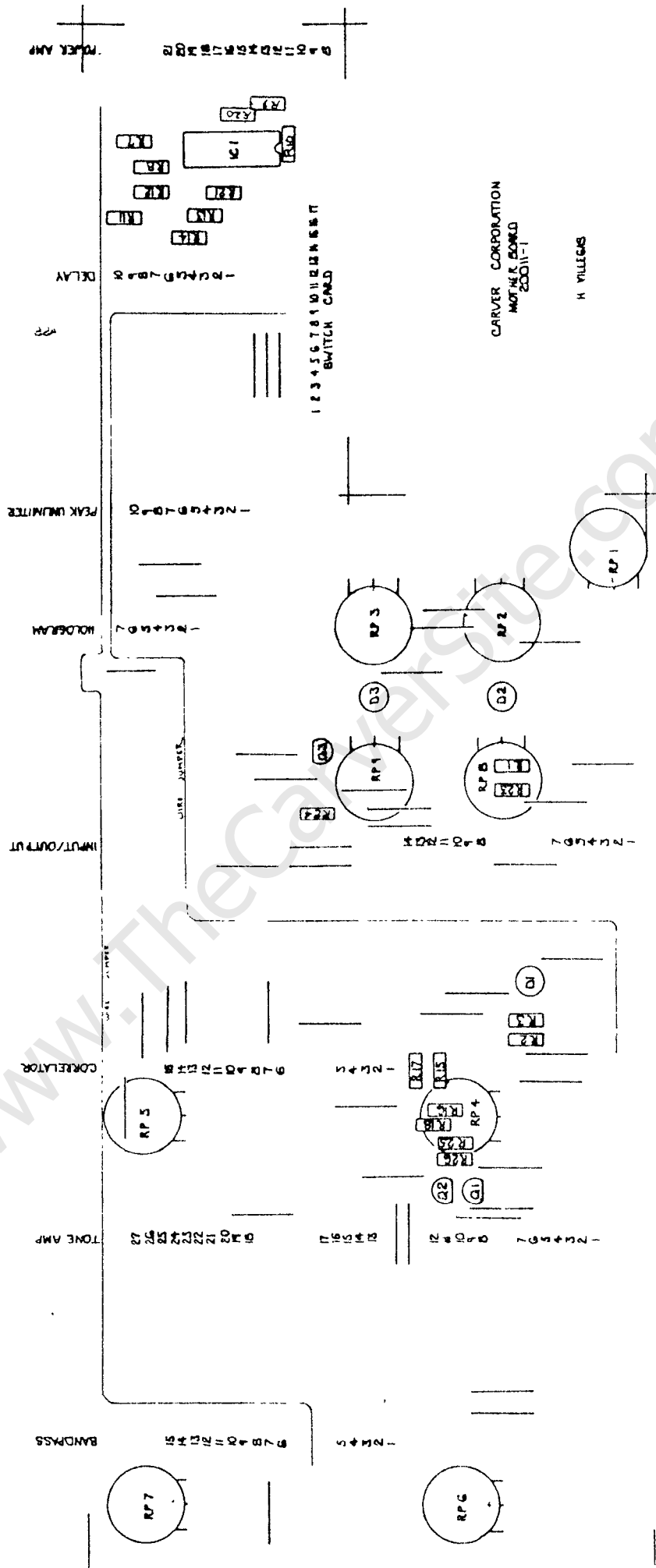

1. MOTHERBOARD ASSEMBLY

| Ref. No | Q'ty | Carver Part No. | Supplier Part No. | Description |
|-----------------------|------|-----------------|-------------------|-----------------|
| Semiconductors | | | | |
| D1~D3 | 3 | | LED – SR505W | LED |
| IC1 | 1 | | 4136 | IC |
| Q1~Q3 | 3 | | 2N5458 | Transistor |
| Resistors | | | | |
| R1 | 1 | | 12Kohm | Carbon Resistor |
| R2 | 1 | | 910ohm | Carbon Resistor |
| R3 | 1 | | 22Kohm | Carbon Resistor |
| R5,R16,R18,R23 | 4 | | 15Kohm | Carbon Resistor |
| R6 | 1 | | 1.5Kohm | Carbon Resistor |
| R7,R9-R11,R13,14 | 6 | | 820ohm | Carbon Resistor |
| R8,R12 | 2 | | 47Kohm | Carbon Resistor |
| R15,R17 | 2 | | 220ohm | Carbon Resistor |
| R20,21 | 2 | | 10Kohm | Carbon Resistor |
| R24~R26 | 3 | | 3.3Kohm | Carbon Resistor |
| Potentiometers | | | | |
| RP1 | 1 | | 25Kohm | Potentiometers |
| RP2,3,9 | 3 | | 20Kohm | Potentiometers |
| RP4~RP7 | 4 | | 50Kohm | Potentiometers |
| RP8 | 1 | | 2Kohm | Potentiometers |

www.TheCarverSite.com

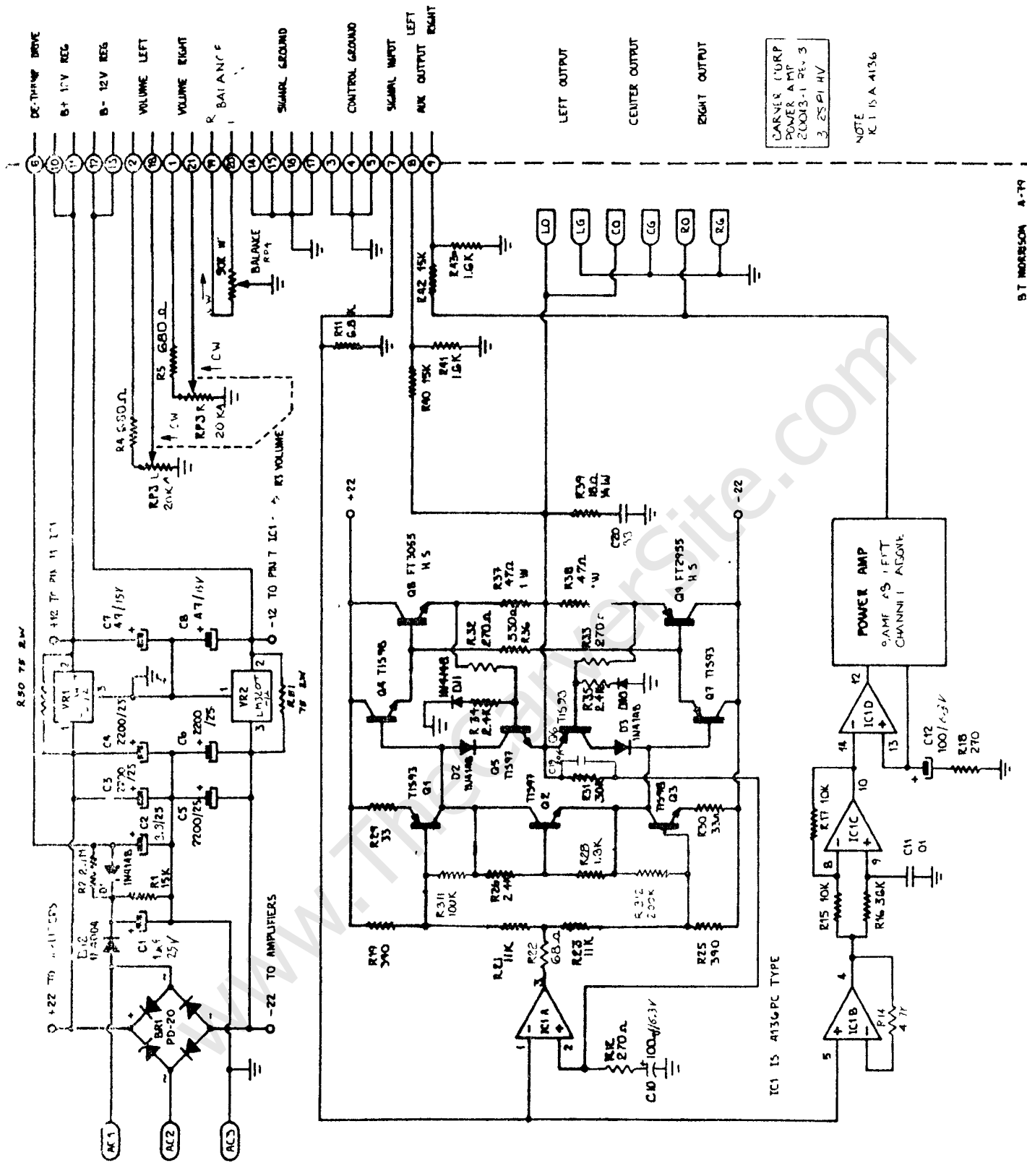

IC1 IS A136-PC TYPE
 IC2 IS A136

NOTE
 IC1 IS A 4136

CARVER
 MODEL C-4000
 POWER SUPPLY/
 POWER AMP PCB
 Schematic

CARVER CORP.
 20013-1
 C-4000 POWER SUPPLY

CARVER MODEL C-4000 POWER SUPPLY/POWER AMP PCB Parts Locator

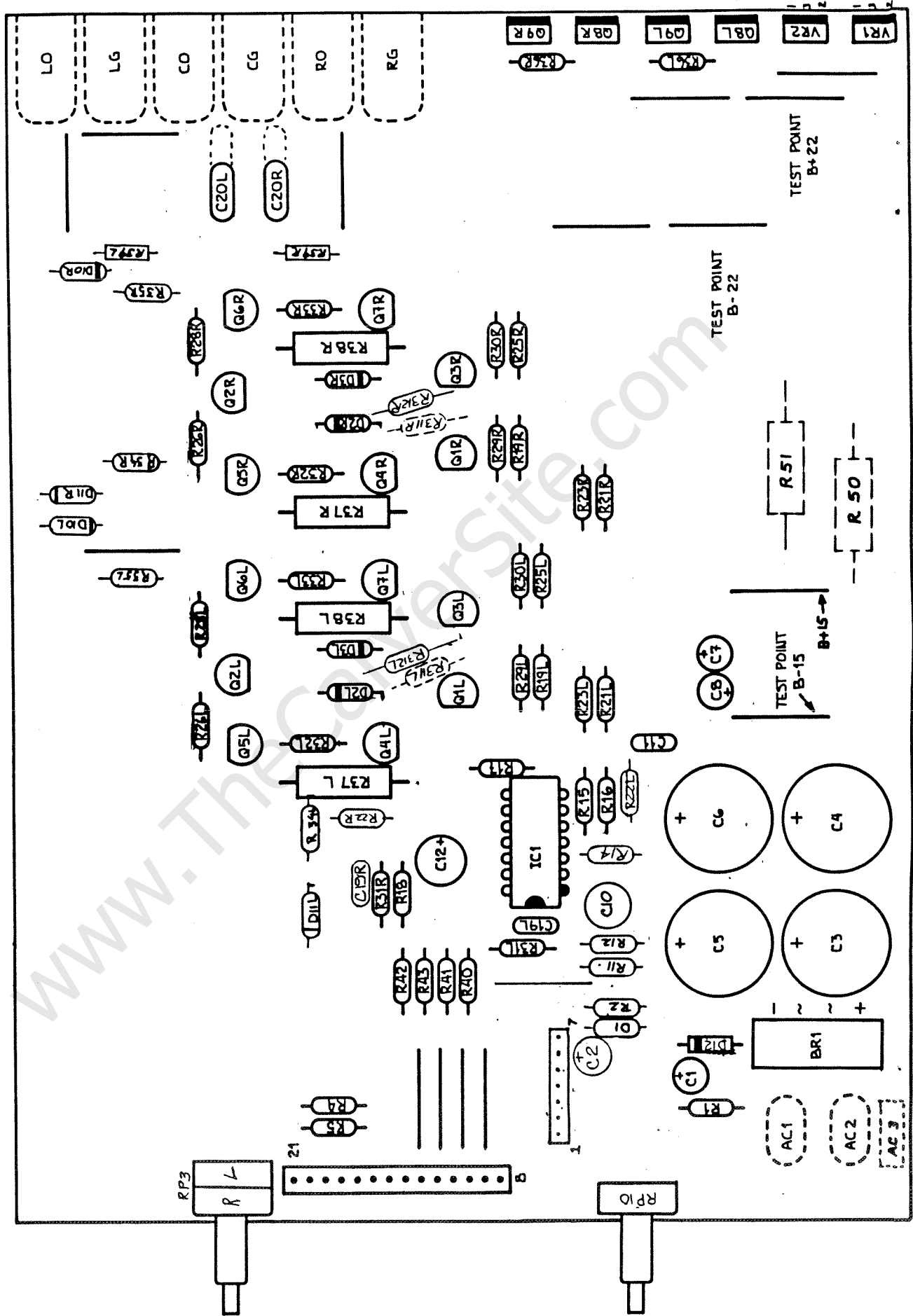

2. Power Supply - Power Amp

| Ref. No | Q'ty | Carver Part No. | Supplier Part No. | Description |
|-----------------------|------|-----------------|-------------------|--------------------------------------|
| Semiconductors | | | | |
| BR1 | 1 | | PD-20 | Bridge Rectifier |
| D1~D3,D10,11 | 9 | | 1N4148 | Diode |
| D12 | 1 | | 1N4004 | Diode |
| IC1 | 1 | | 4136 | IC |
| Q1,Q6,Q7 | 6 | | MPS8093? | Transistor |
| Q2,Q5 | 4 | | MPS8097? | Transistor |
| Q3,Q4 | 4 | | ????? | Transistor |
| Q8 | 2 | | MJE3055 | Transistor |
| Q9 | 2 | | MJE2955 | Transistor |
| VR1 | 1 | | 7812C | Voltage regulator |
| VR2 | 1 | | LM320t | Voltage regulator |
| Capacitors | | | | |
| C1 | 1 | | 1uf - 25v | Electrolytic Capacitor |
| C2 | 1 | | 3.3uf - 25v | Electrolytic Capacitor |
| C3~C6 | 4 | | 2200uf - 25v | Electrolytic Capacitor |
| C7,C8 | 2 | | 47uf - 15v | Electrolytic Capacitor |
| C10,12 | 2 | | 100uf - 6.3v | Electrolytic Capacitor |
| C11 | 1 | | .01uf | |
| C19 | 2 | | ????? | on locator print, not schematic |
| C20 | 2 | | .33? | |
| Resistors | | | | |
| R1,40,42 | 6 | | 15Kohm | Resistor |
| R2 | 1 | | 2.1Mohm | Resistor |
| R4,5 | 4 | | 680ohm | Resistor |
| R11 | 2 | | 6.8Kohm | Resistor |
| R12,18,32,33 | 8 | | 270ohm | Resistor |
| R14 | 2 | | 4.7Kohm | Resistor |
| R15,17 | 4 | | 10Kohm | Resistor |
| R16 | 2 | | 36Kohm | Resistor |
| R19 | 2 | | 340ohm | Resistor |
| R21,23 | 4 | | 11Kohm | Resistor |
| R22 | 2 | | 68ohm | Resistor |
| R25 | 2 | | 390ohm | Resistor |
| R26,34,35 | 6 | | 2.4Kohm | Resistor |
| R28 | 2 | | 1.3Kohm | Resistor |
| R29,30 | 4 | | 33ohm | Resistor |
| R31 | 2 | | 30Kohm | Resistor |
| R36 | 2 | | 330ohm | Resistor |
| R37,38 | 4 | | 47ohm 1W | Resistor |
| R39 | 2 | | 18ohm 1/4w | Resistor |
| R41,43 | 4 | | 1.6Kohm | Resistor |
| R50 | 2 | | ????? | on locator print |
| R51 | 2 | | ????? | not on schematic |
| R311 | 2 | | 100Kohm | Resistor |
| R312 | 2 | | 200Kohm | Resistor |
| Potentiometers | | | | |
| RP3 | 2 | | 20Kohm | Potentiometer |
| RP4 | 2 | | 50Kohm | Potentiometer |
| RP10 | 2 | | ????? | not on schematic on locator print |

PHONO AMP SUB-SONIC FILTER
 20009-1 21V 1
 SCHEMATIC DIAGRAM
 3-23 61 11V SMT 1 OF 2

CARVER CORPORATION
 EVERETT, WASH

CARVER MODEL C-4000
 PHONO Schematic

Page 1 of 2

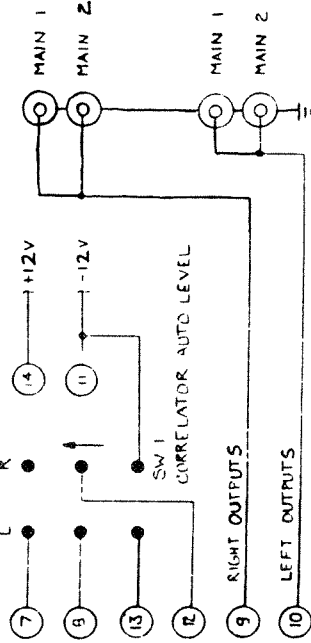
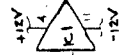
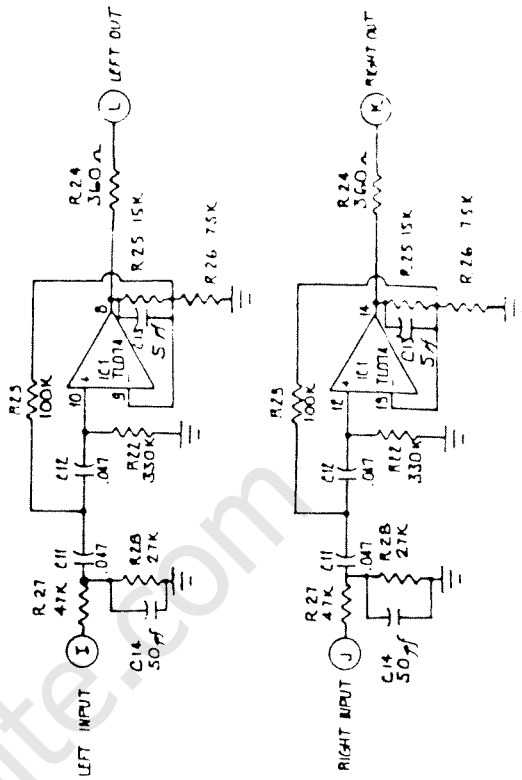
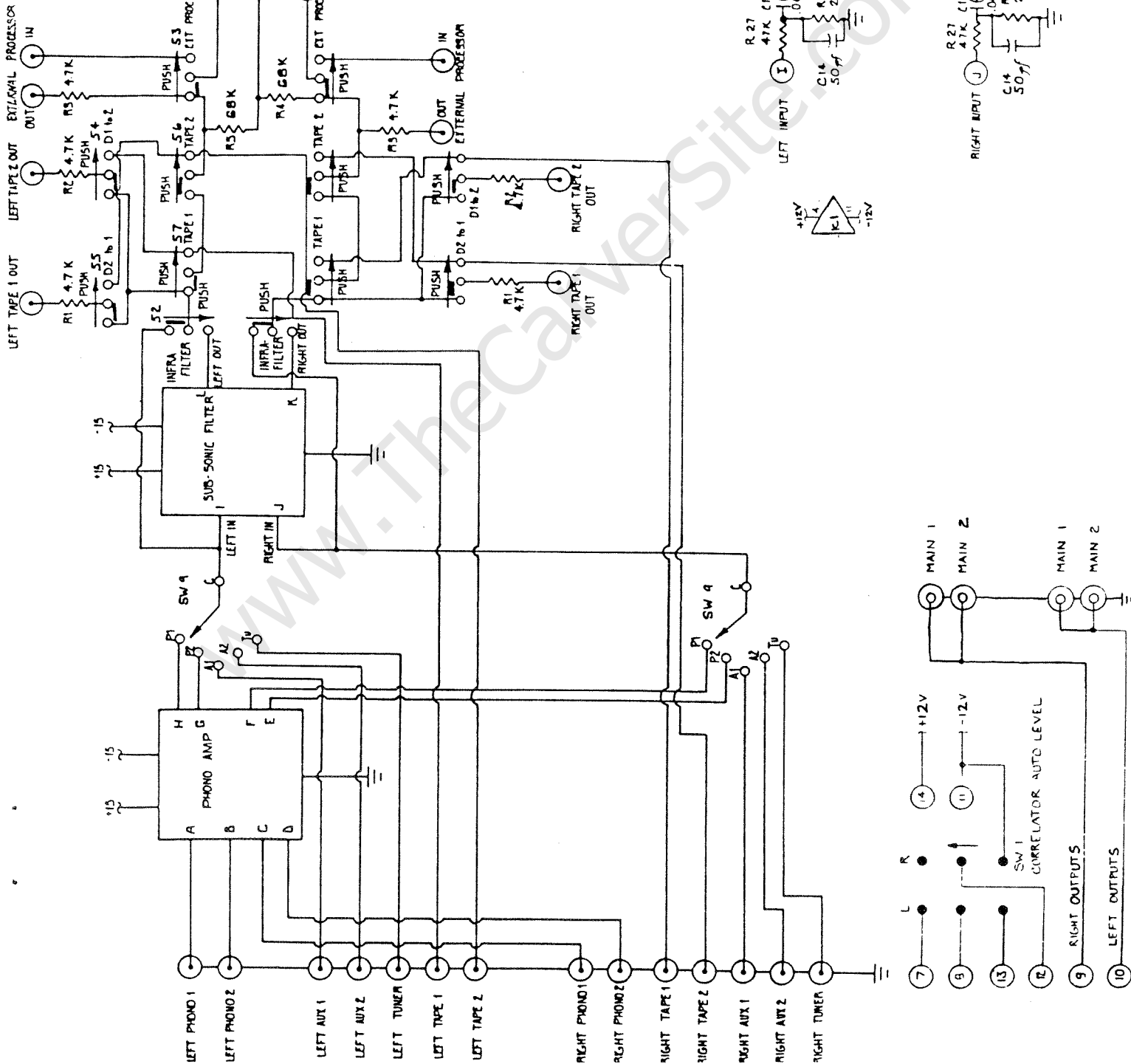

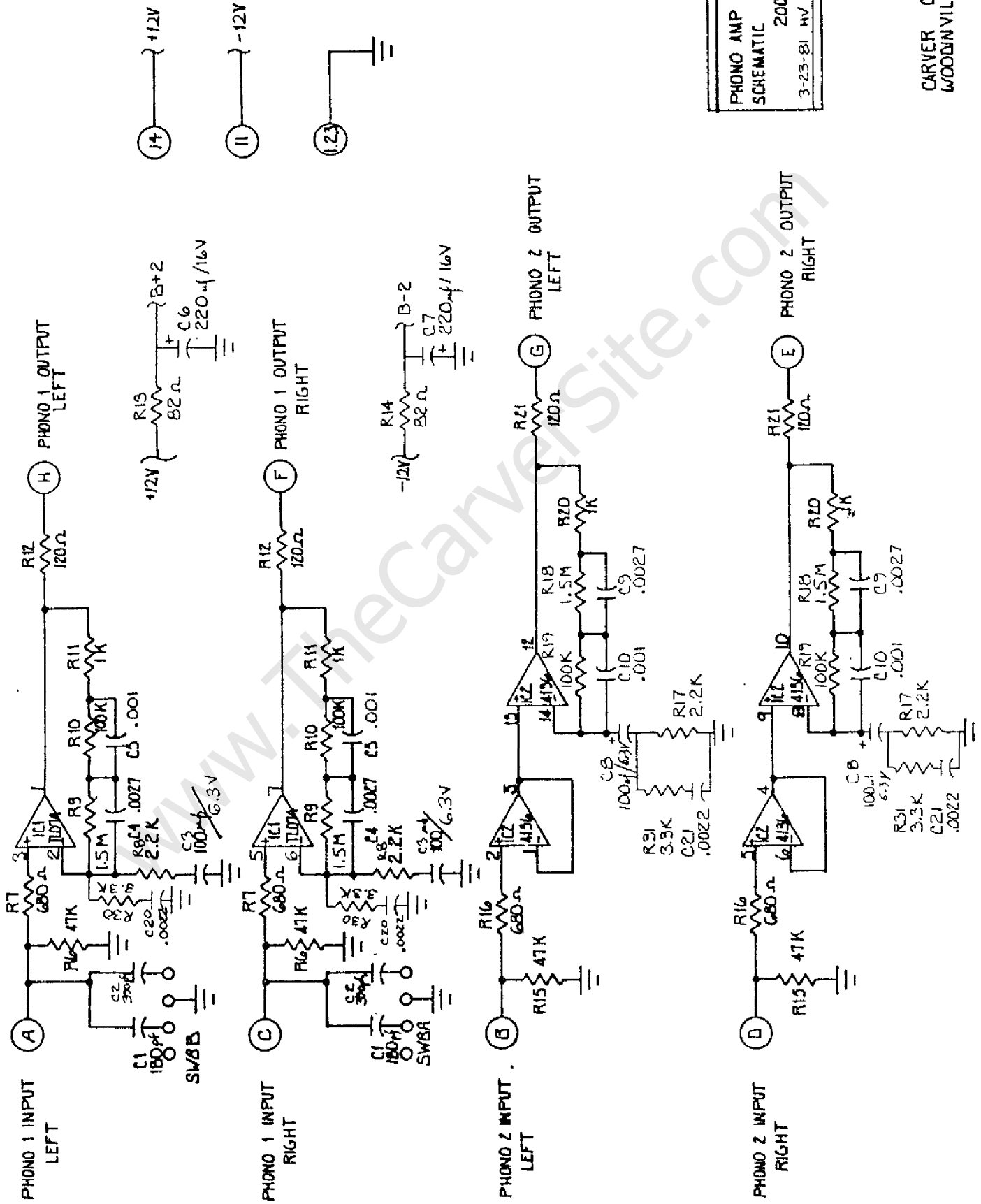

PHONO AMP / SUBSONIC FILTER
 SCHEMATIC DIAGRAM
 20005-1 REV 1
 3-23-81 HV SHT 2 OF 2

CARVER CORPORATION
 WOODBURNVILLE, WA

3. Phono

| Ref. No | Q'ty | Carver Part No. | Supplier Part No. | Description |
|-----------------------|------|-----------------|-------------------|--------------|
| Semiconductors | | | | |
| IC1 | 1 | | TL074 | IC |
| IC2 | 1 | | 4136 | IC |
| Capacitors | | | | |
| C1 | 2 | | 180pf | Ceramic |
| C2 | 2 | | 390pf | Ceramic |
| C3,C8 | 4 | | 100uf - 6.3v | Electrolytic |
| C4,C9 | 4 | | .0027uf | Ceramic |
| C5,C10 | 4 | | .001uf | Ceramic |
| C6,C7 | 2 | | 220uf - 16v | Electrolytic |
| C11,12 | 4 | | .047uf | Ceramic |
| C13 | 2 | | 5pf | Ceramic |
| C14 | 2 | | 50pf | Ceramic |
| C20,21 | 4 | | .0022uf | Ceramic |
| Resistors | | | | |
| R1~R3 | 6 | | 4.7Kohm | Resistor |
| R4,5 | 2 | | 68Kohm | Resistor |
| R6,R15,R27 | 6 | | 47Kohm | Resistor |
| R7,R16 | 4 | | 680ohm | Resistor |
| R8,R17 | 4 | | 2.2Kohm | Resistor |
| R9,R18 | 4 | | 1.5Mohm | Resistor |
| R10,R19,R23 | 6 | | 100Kohm | Resistor |
| R11,R20 | 4 | | 1Kohm | Resistor |
| R12,R21 | 4 | | 120ohm | Resistor |
| R13,14 | 4 | | 82ohm | Resistor |
| R22 | 2 | | 330Kohm | Resistor |
| R24 | 2 | | 360ohm | Resistor |
| R25 | 2 | | 15Kohm | Resistor |
| R26 | 2 | | 75Kohm | Resistor |
| R28 | 2 | | 27Kohm | Resistor |
| R30,31 | 4 | | 3.3Kohm | Resistor |
| Switch | | | | |
| SW1 | 1 | | | Switch |
| S2 | 1 | | | Switch |
| S3 | 1 | | | Switch |
| S4 | 1 | | | Switch |
| S5 | 1 | | | Switch |
| S6 | 1 | | | Switch |
| S7 | 1 | | | Switch |
| SW8A,B | 1 | | | Switch |
| SW9 | 1 | | | Switch |

LEFT OUTPUTS

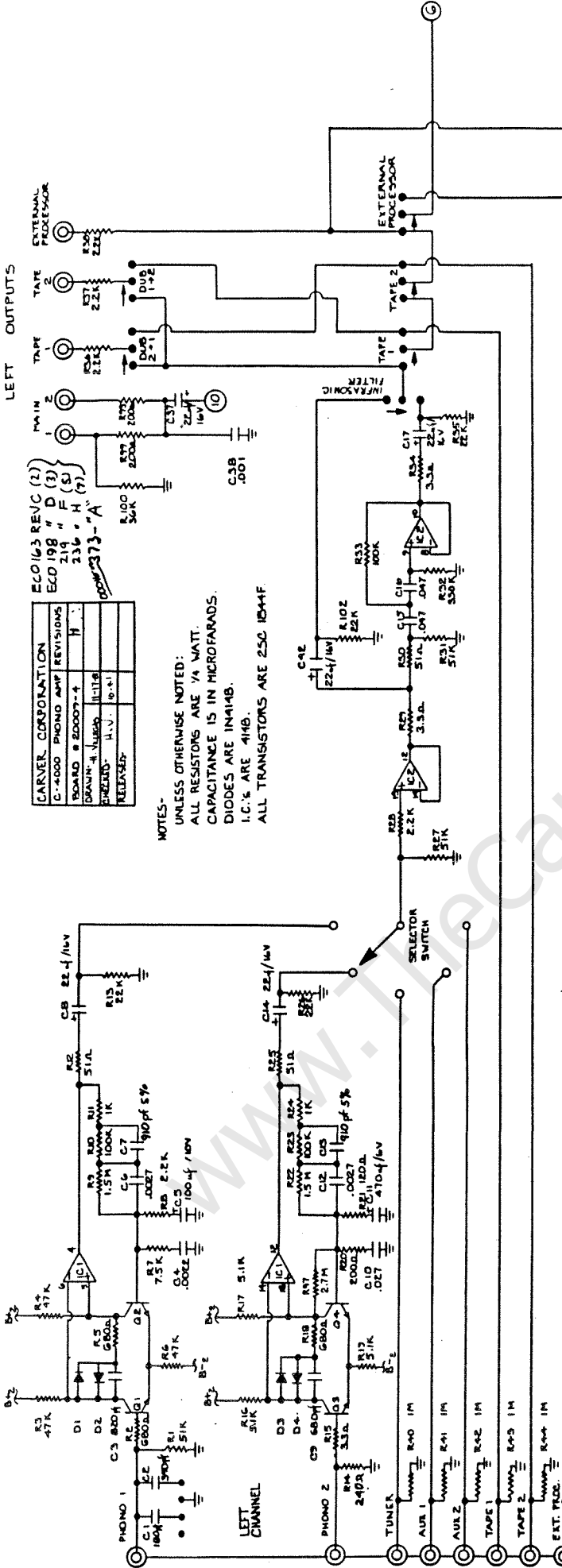

ECO163 REV C (2)
 ECD 198 " F (3)
 219 " F (5)
 136 " H (7)

| | |
|----------------------------|-----------|
| CARVER CORPORATION | |
| C-4000 PHONO AMP REVISIONS | |
| BOARD # 20007-4 | H |
| DRUMIN # NUMBER | 11-118 |
| REVISIONS | 1-1-1 0-1 |
| RELEASED | |

NOTES:
 UNLESS OTHERWISE NOTED:
 ALL RESISTORS ARE 1/4 WATT.
 CAPACITANCE IS IN MICROFARADS.
 DIODES ARE 1N4148.
 I.C.'s ARE 4148.
 ALL TRANSISTORS ARE 2SC 1844F.

RIGHT OUTPUTS

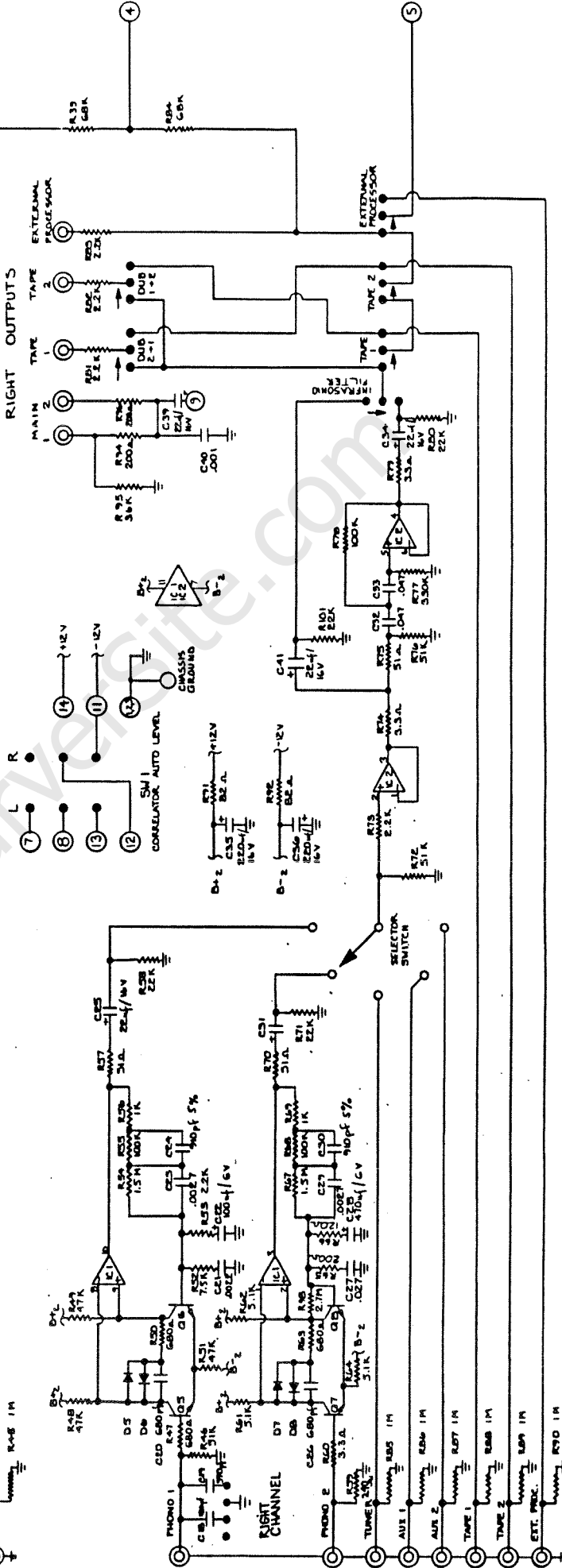

CONVERTER AUTO LEVEL
 SW 1
 12V
 11V
 10V
 9V
 8V
 7V

CARVER C-4000 PHONO PCB Parts Locator

- 1 } GROUND
- 2 }
- 3 }
- 4 L+R OUT TO SUM
- 5 RIGHT OUT TO CORRELATOR
- 6 LEFT OUT TO CORRELATOR
- 7 L PUSH
- 8 L CENTER
- 9 MAIN OUT R
- 10 MAIN OUT L
- 11 -12V
- 12 R CENTER
- 13 L RELEASED
- 14 +12V

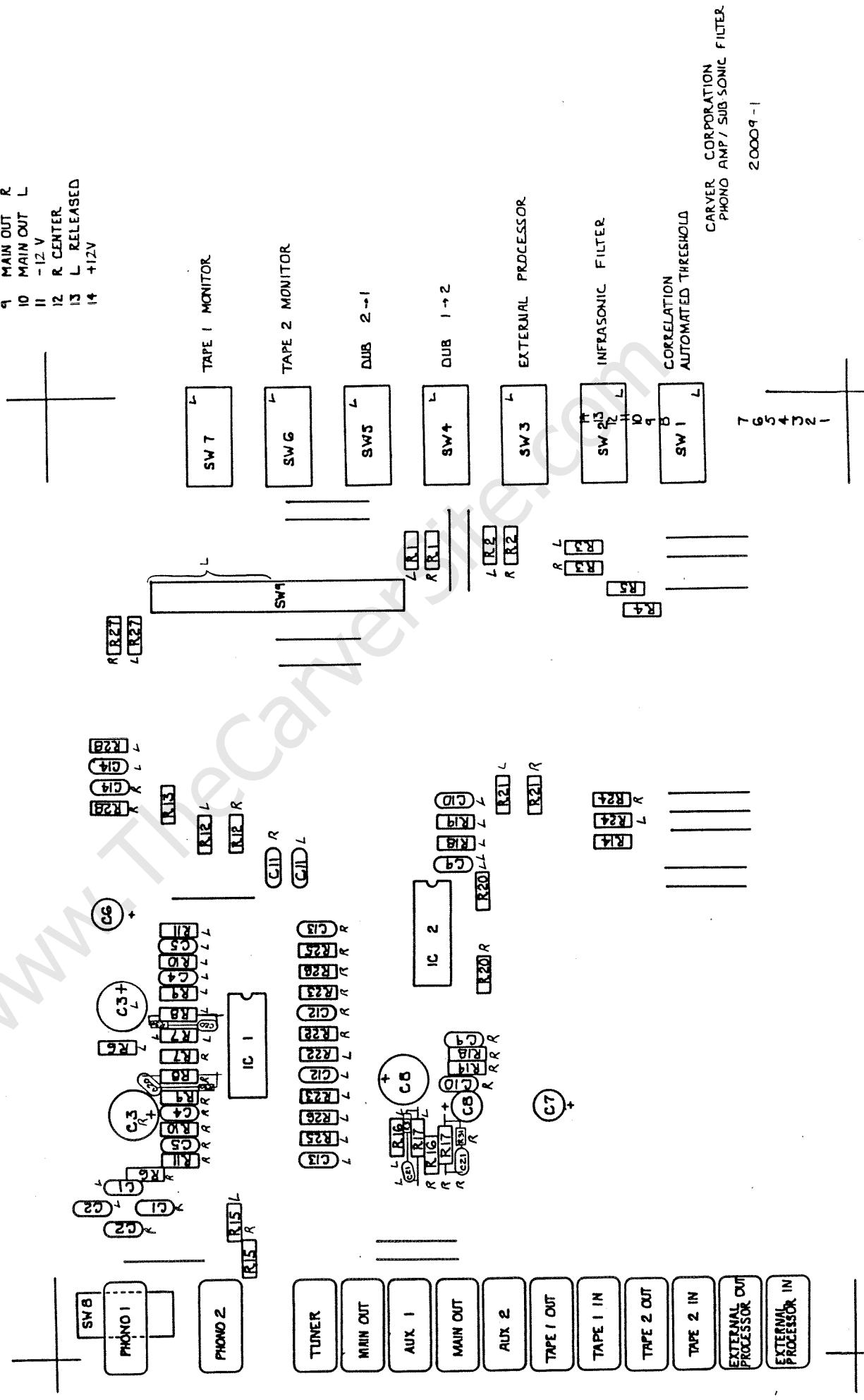

CARVER CORPORATION
PHONO AMP / SUB SONIC FILTER
20009-1

CARVER CORPORATION
PHONO AMP - 20009-4

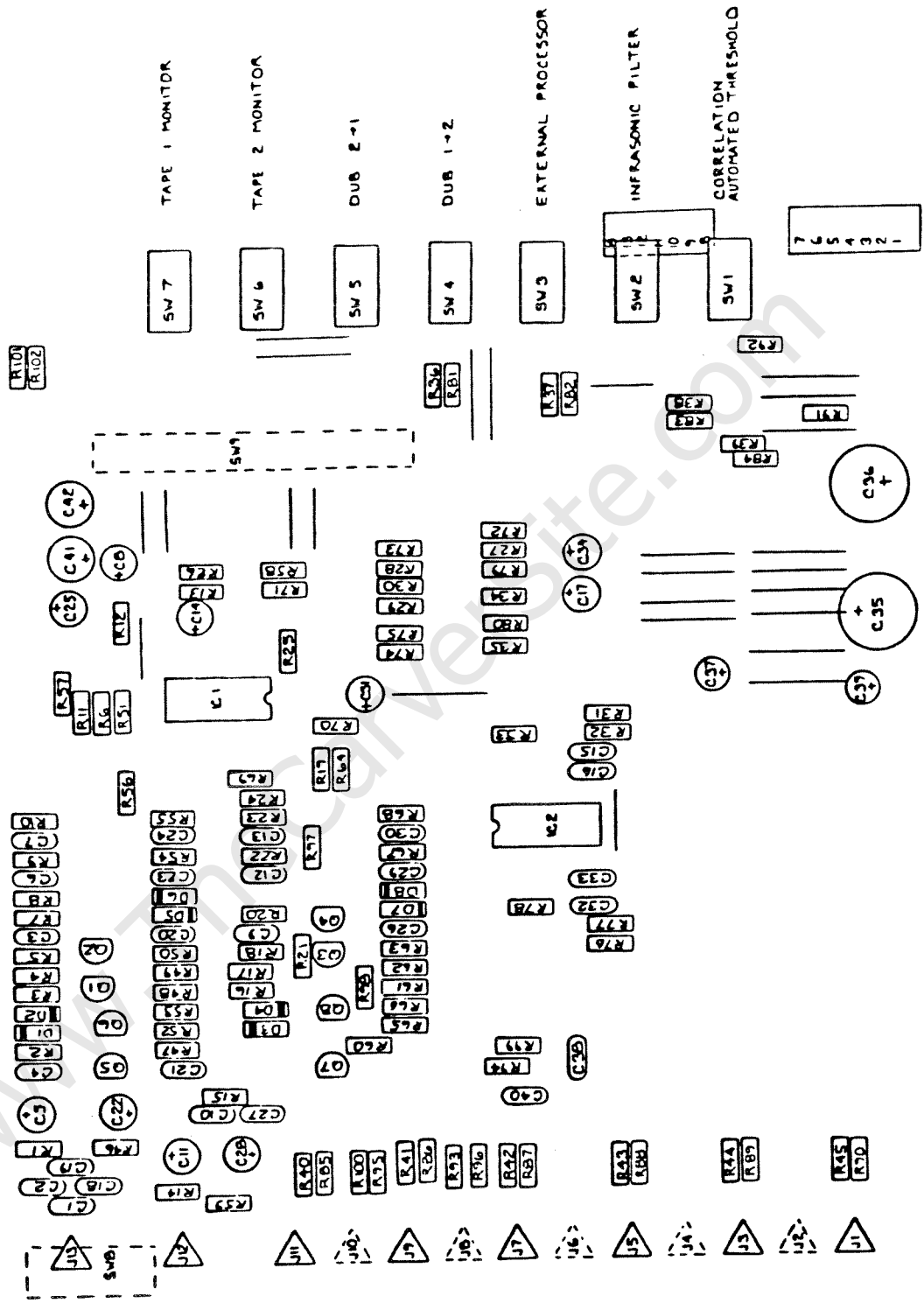

INTERCONNECTS-

- 1 } GROUND
- 2 }
- 3 }
- 4 L R OUT - TO SW1
- 5 R OUT - TO CORRELATOR
- 6 L OUT - TO CORRELATOR
- 7 L PUSHER SW1
- 8 L CENTER SW1
- 9 MAIN OUT R
- 10 MAIN OUT L
- 11 -12 V
- 12 R CENTER SW1
- 13 L RELEASED SW1

JACKS

- J1 EXT PROCESSOR - IN
- J2 EXT PROCESSOR - OUT
- J3 TAPE 2 - IN
- J4 TAPE 2 - OUT
- J5 TAPE 1 - IN
- J6 TAPE 1 - OUT
- J7 AUX 2
- J8 MAIN OUT 2
- J9 AUX 1
- J10 MAIN OUT 1
- J11 TUNER
- J12 PHONO 2
- J13 PHONO 1

CARVER C-4000 PHONO PCB Parts Locator

- 1 } GROUND
- 2 }
- 3 }
- 4 L + R OUT - TO SUM
- 5 RIGHT OUT - TO CORRELATOR
- 6 LEFT OUT - TO CORRELATOR
- 7 L - PUSH
- 8 L CENTER
- 9 MAIN OUT R
- 10 MAIN OUT L
- 11 - 12 V
- 12 R CENTER
- 13 L CENTER
- 14 +12V

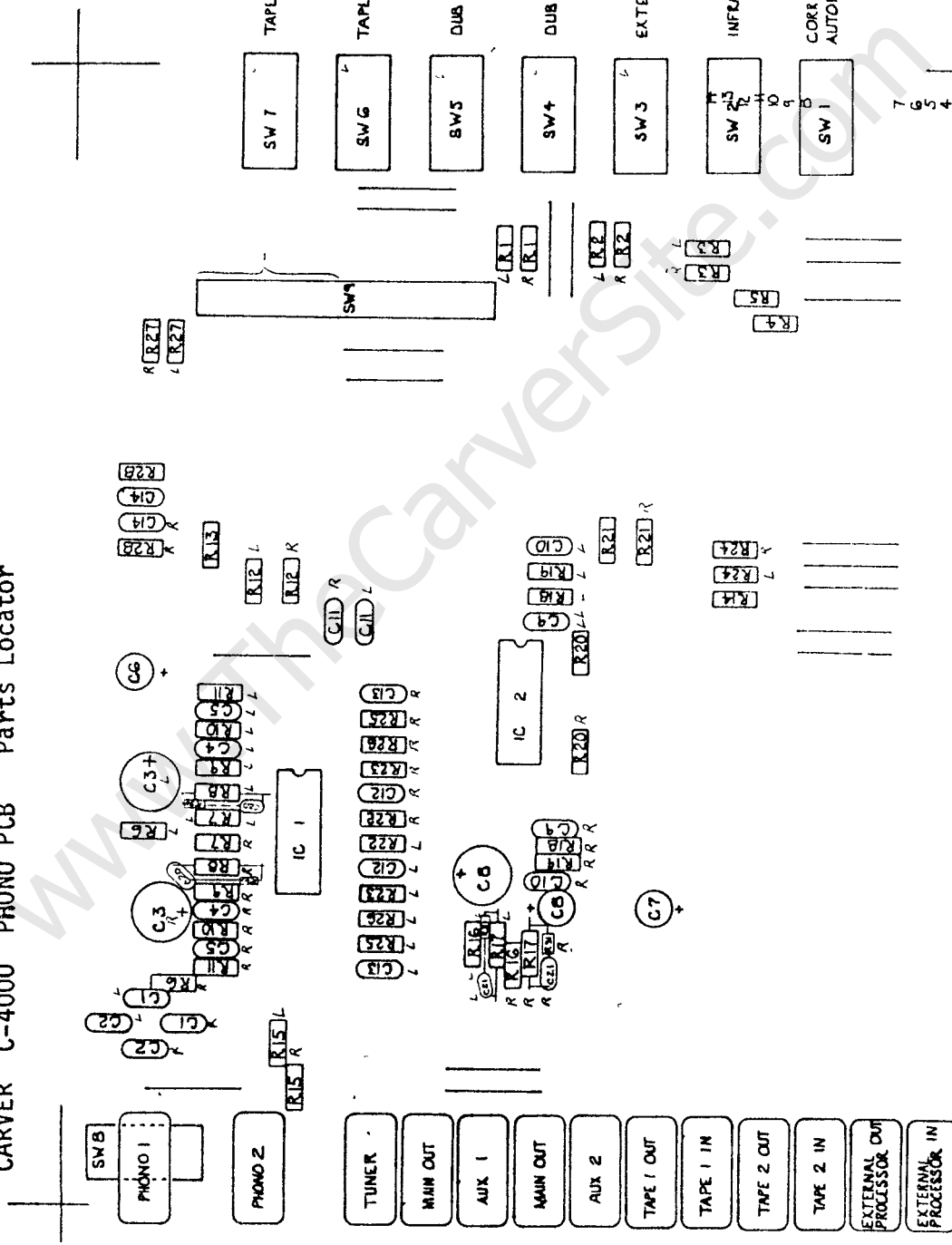

CARVER CORPORATION
PHONO AMP / SUB SONIC FILTER
20009 1

4. Peak Unlimiter

| Ref. No | Q'ty | Carver Part No. | Supplier Part No. | Description |
|-------------------|------|-----------------|-------------------|--------------|
| Capacitors | | | | |
| C1 | 2 | | 22uf – 50v | Electrolytic |
| C2 | 2 | | 22uf – 50v | Electrolytic |
| C3 | 1 | | .1uf | |
| C4 | 1 | | 1uf ? | |
| C5 | 1 | | 47uf – 35v | Electrolytic |
| C6 | 1 | | 47uf – 10v | Electrolytic |
| C7 | 2 | | 4.7uf – 6.3v | Electrolytic |
| C8 | 1 | | .0047uf | |
| Resistors | | | | |
| R1,11 | 2 | | 68Kohm | Resistor |
| R2 | 2 | | 10Kohm | Resistor |
| R3,6,7 | 2 | | 12Kohm | Resistor |
| R4,24 | 2 | | 56Kohm | Resistor |
| R5 | 2 | | 39Kohm | Resistor |
| R8,18 | 2 | | 3.9Kohm | Resistor |
| R9 | 2 | | 22Kohm | Resistor |
| R10 | 2 | | 3.9Kohm | Resistor |
| R14-16 | 3 | | 36Kohm | Resistor |
| R17 | 1 | | 12Kohm | Resistor |
| R19 | 1 | | 220ohm | Resistor |
| R20 | 1 | | 680ohm | Resistor |
| R21 | 1 | | 1.2Kohm | Resistor |
| R22 | 1 | | 180Kohm | Resistor |
| R23 | 1 | | 680Kohm | Resistor |
| R25,26 | 1 | | 18Kohm | Resistor |
| R27 | 1 | | 1Kohm | Resistor |

CARVER MODEL C-4000 PEAK UNLIMITER Schematic

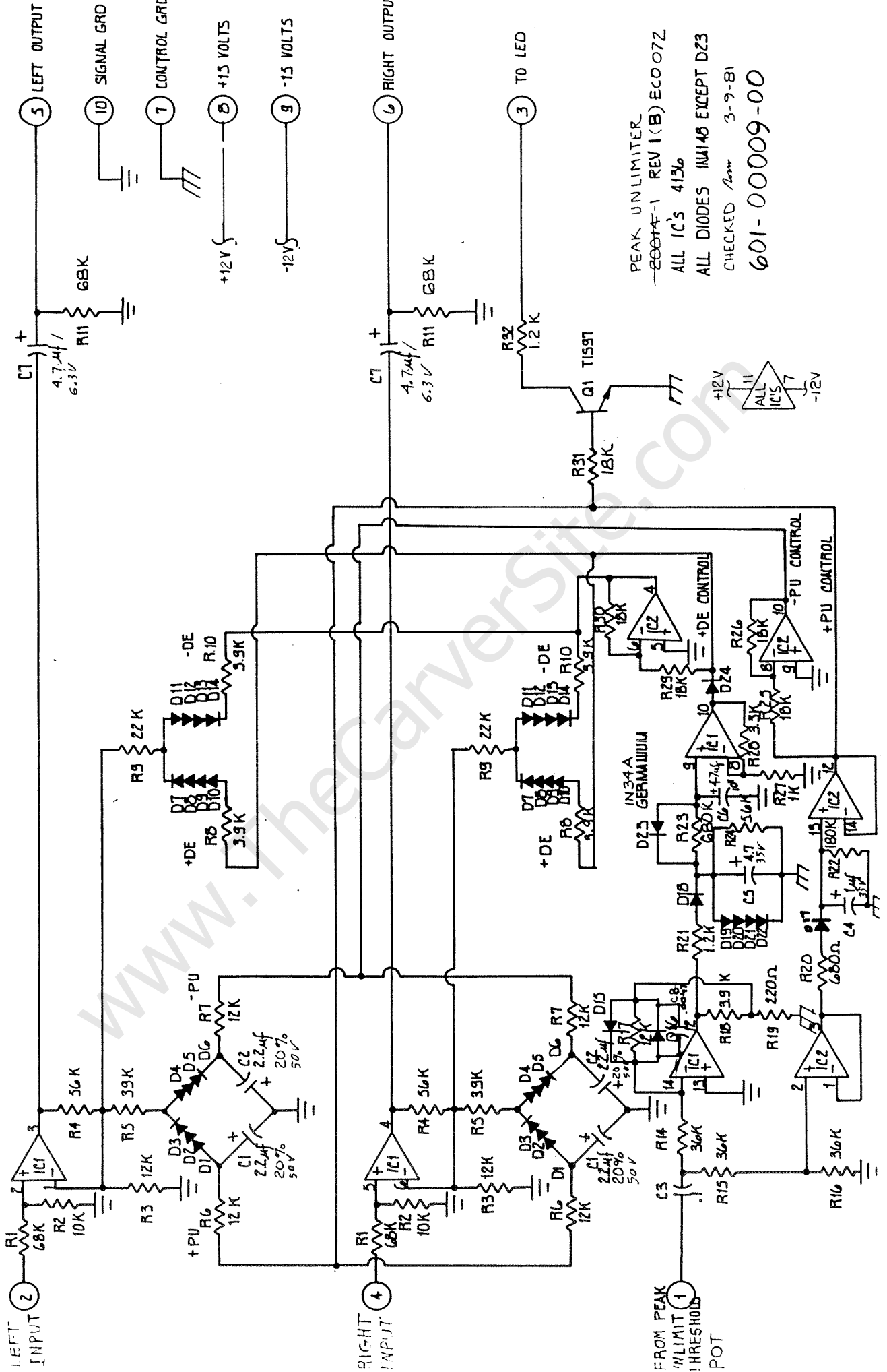

PEAK UNLIMITER
~~2007F-1~~ REV I (B) ECO 072
 ALL IC'S 4136
 ALL DIODES 1N4148 EXCEPT D23
 CHECKED /mm 3-9-81
 601-00009-00

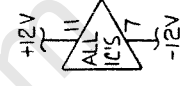

CARVER MODEL C-4000 PEAK UNLIMITER PCB Parts Locator

SIGNAL GROUND
 +12 VOLTS
 CONTROL GROUND
 RIGHT OUTPUT
 LEFT OUTPUT
 RIGHT INPUT
 TO LED
 LEFT INPUT
 CONTROL INPUT

10967654321

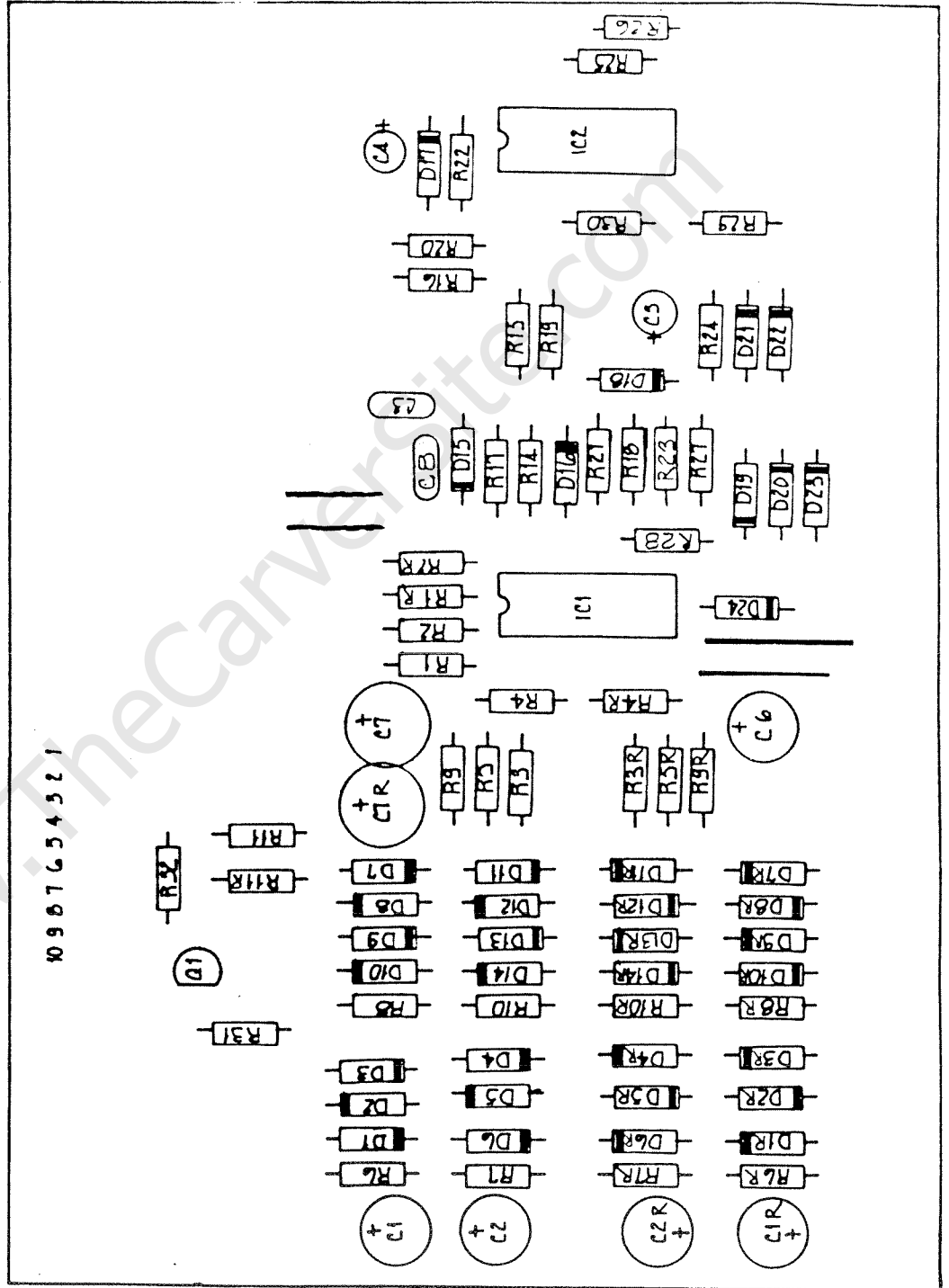

5. Correlator

| Ref. No | Q'ty | Carver Part No. | Supplier Part No. | Description |
|-----------------------|------|-----------------|-------------------|--------------------|
| Semiconductors | | | | |
| D3,4,6,8,10,11 | 2 | | 1N4148 | Diode |
| D14,15,18,19,22,23 | 2 | | 1N4148 | Diode |
| IC1 | 1 | | 4136 | Integrated Circuit |
| IC2 | 1 | | 4136 | Integrated Circuit |
| IC3 | 1 | | 4136 | Integrated Circuit |
| IC4 | 1 | | 4136 | Integrated Circuit |
| Capacitors | | | | |
| C1 | 2 | | .047uf | Capacitor |
| C2,3,7 | 2 | | .001uf | Capacitor |
| C4,18 | 2 | | .0022uf | Capacitor |
| C5,6,12,16 | 2 | | 500pf | Capacitor |
| C8,9 | 2 | | .022uf | Capacitor |
| C10,11,14,15,19,101 | 2 | | 250pf | Capacitor |
| C13,17,23 | 2 | | .01uf | Capacitor |
| C20,104,105,106 | 2 | | .1uf | Capacitor |
| C107,108,109,110 | 2 | | .1uf | Capacitor |
| C111,112,115 | 2 | | .1uf | Capacitor |
| C21 | 2 | | .0068uf | Capacitor |
| C22,113,114 | 2 | | 2.2uf - 50v | Electrolytic |
| C117 | 2 | | 4.7uf - 6.3v | Electrolytic |
| C100 | 2 | | 470pf | Capacitor |
| C102,103 | 2 | | 120pf | Capacitor |
| Resistors | | | | |
| R1,14 | 2 | | 680ohm | Resistor |
| R2,11,12,25 | 2 | | 56Kohm | Resistor |
| R4,5,35,47 | 2 | | 4.7Kohm | Resistor |
| R6,7,8,9,16,17,18 | 2 | | 12Kohm | Resistor |
| R19,26,27,28,29 | 2 | | 12Kohm | Resistor |
| R36,37,38,39,40,41 | 2 | | 12Kohm | Resistor |
| R48,49 | 2 | | 12Kohm | Resistor |
| R10 | 2 | | 10Kohm | Resistor |
| R13,57 | 2 | | 27Kohm | Resistor |
| R15,52 | 2 | | 5.6Kohm | Resistor |
| R20 | 2 | | 360Kohm | Resistor |
| R21,22 | 2 | | 68Kohm | Resistor |
| R23 | 2 | | 33Kohm | Resistor |
| R24,34,46 | 2 | | 820ohm | Resistor |
| R31,32 | 2 | | 82Kohm | Resistor |
| R33 | 2 | | 39Kohm | Resistor |
| R42 | 2 | | 100ohm | Resistor |
| R43,44 | 2 | | 47Kohm | Resistor |
| R45 | 2 | | 24Kohm | Resistor |
| R50 | 2 | | 3.3Kohm | Resistor |
| R51 | 2 | | 35Kohm | Resistor |
| R53,54,55,56 | 2 | | 22Kohm | Resistor |
| R58 | 2 | | 270Kohm | Resistor |
| R59 | 2 | | 4.5Kohm | Resistor |
| R60,61 | 2 | | 36Kohm | Resistor |
| R62-R72 | 2 | | 3.9Kohm | Resistor |

CARVER MODEL C-4000 CORRELATOR Schematic

ALL ICs - 4156
ALL DIODES ARE 1N4148

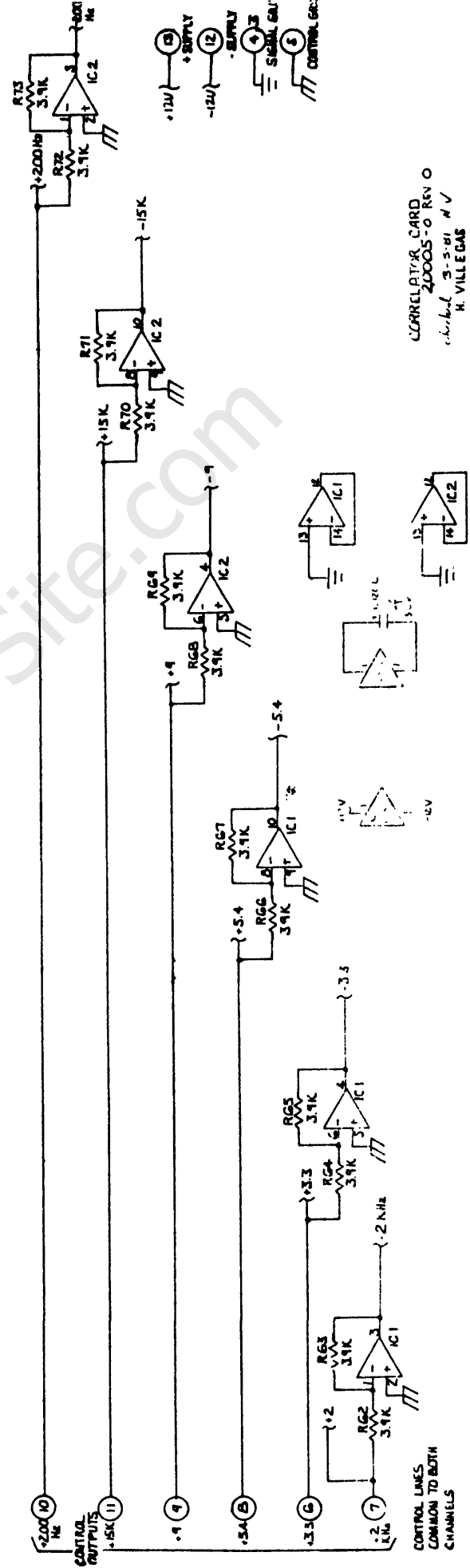
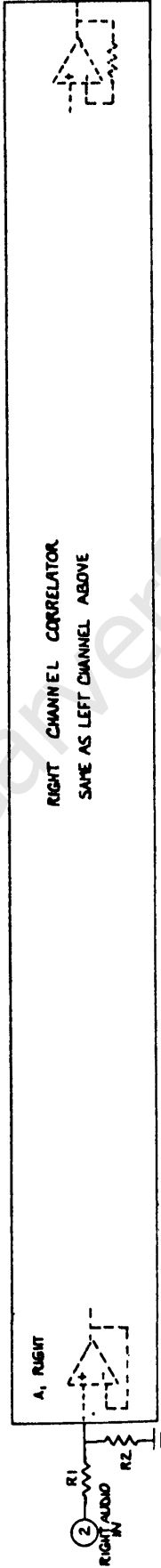
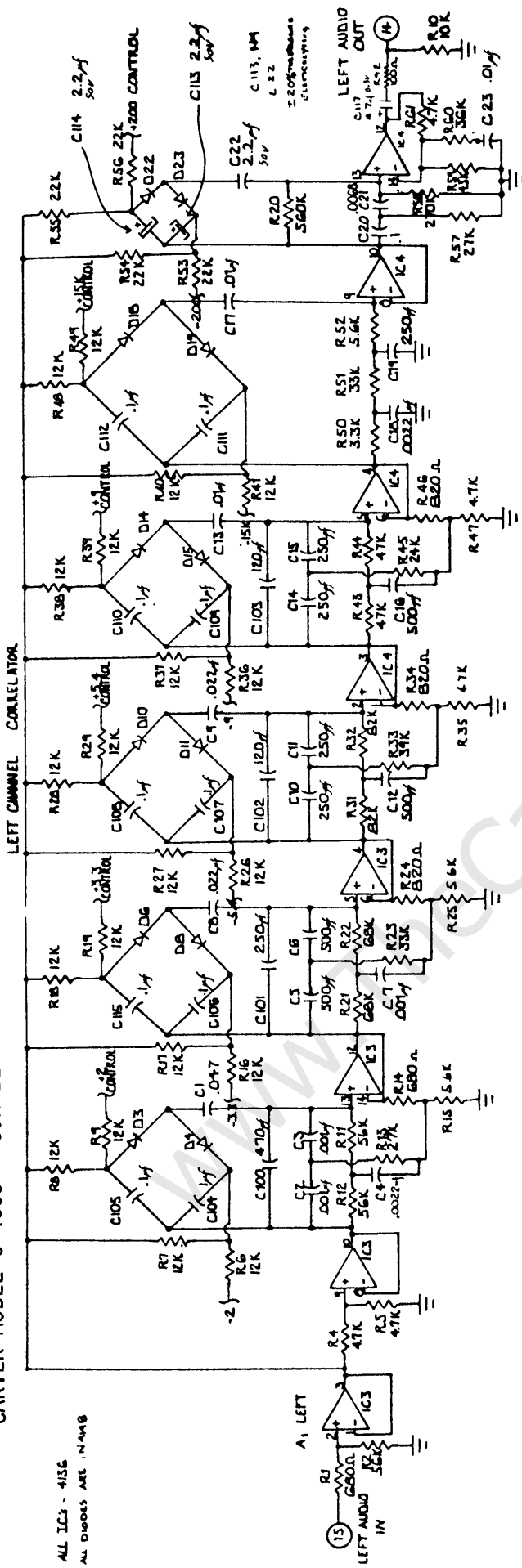

CORRELATOR CARD
2000S-0 REV 0
REV. 3-5-61 M/V
H. VILLE GAS

CONTROL GROUND
 SIGNAL GROUND
 RIGHT CHANNEL
 LEFT CHANNEL

RIGHT CHANNEL

LEFT CHANNEL

CARVER MODEL C-4000

CORRELATOR PCB

Parts Locator

Note: The circuitry on the Correlator board is part of the Auto-correlator.

CORRELATOR DESIGNATION SHEET
 20005-0

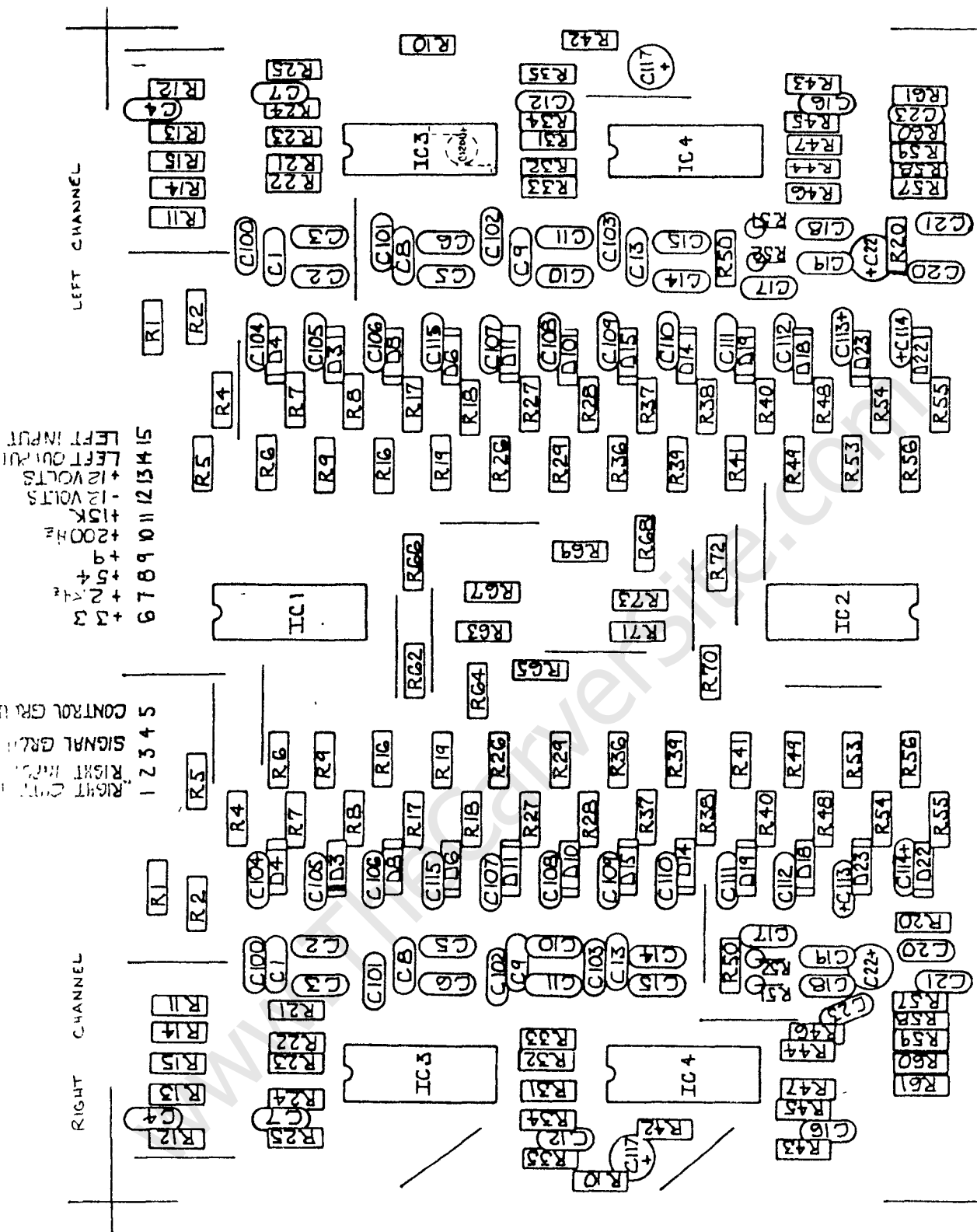

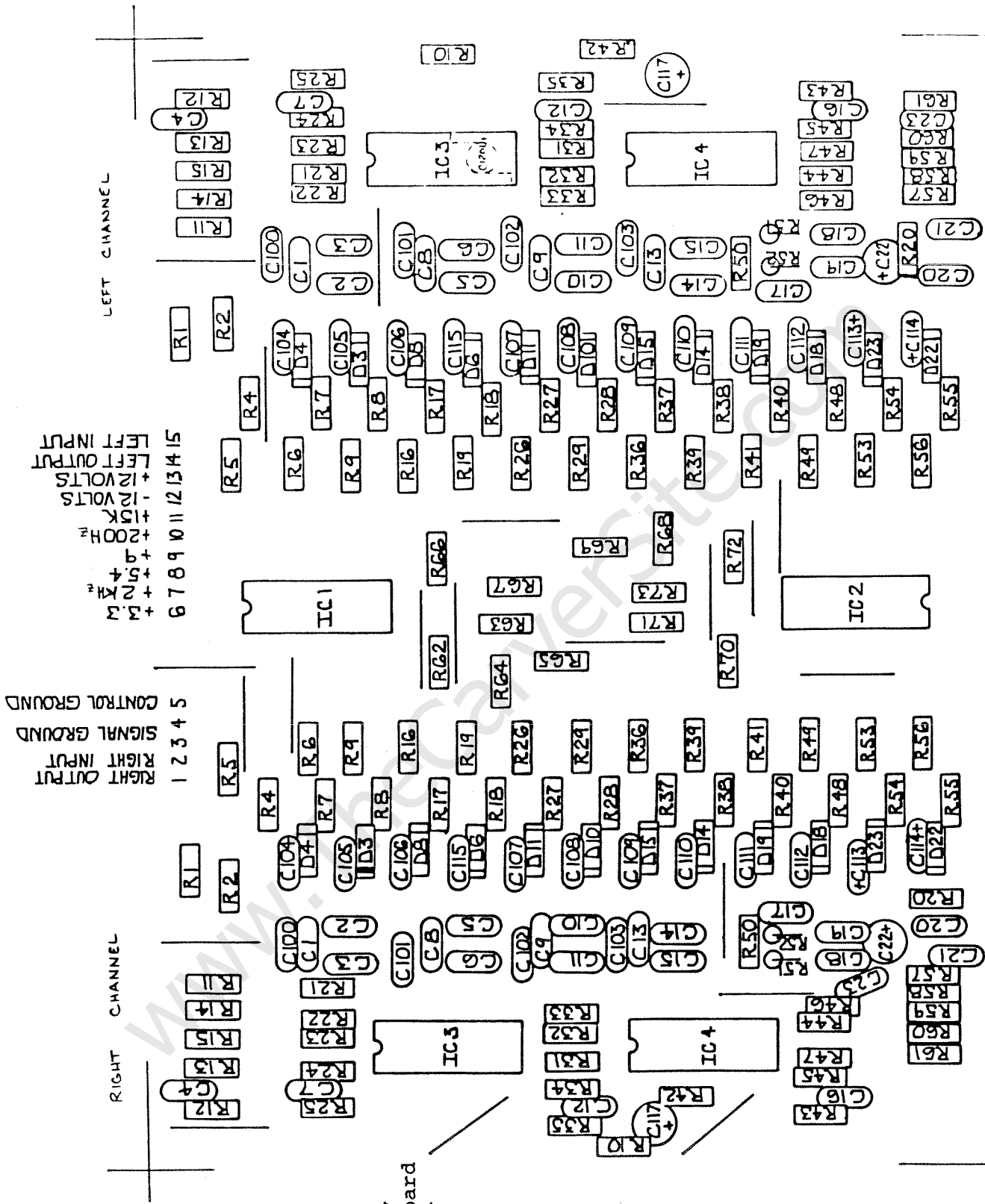

ARVER MODEL C-4000
CORRELATOR PCB
parts Locator

Note: The circuitry on the Correlator board is part of the Auto-correlator.

CORRELATOR
DESIGNATION SHEET
2005-0

00002-00 REYA C-4000

BANDPASS CARD
 CARVER CORPORATION
 EVERETT, WASH.
 SCHEMATIC DIAGRAM
 Checked 3/16/61 DM

NOTES: ALL IC'S ARE 4134
 ALL DIODES ARE IN4148

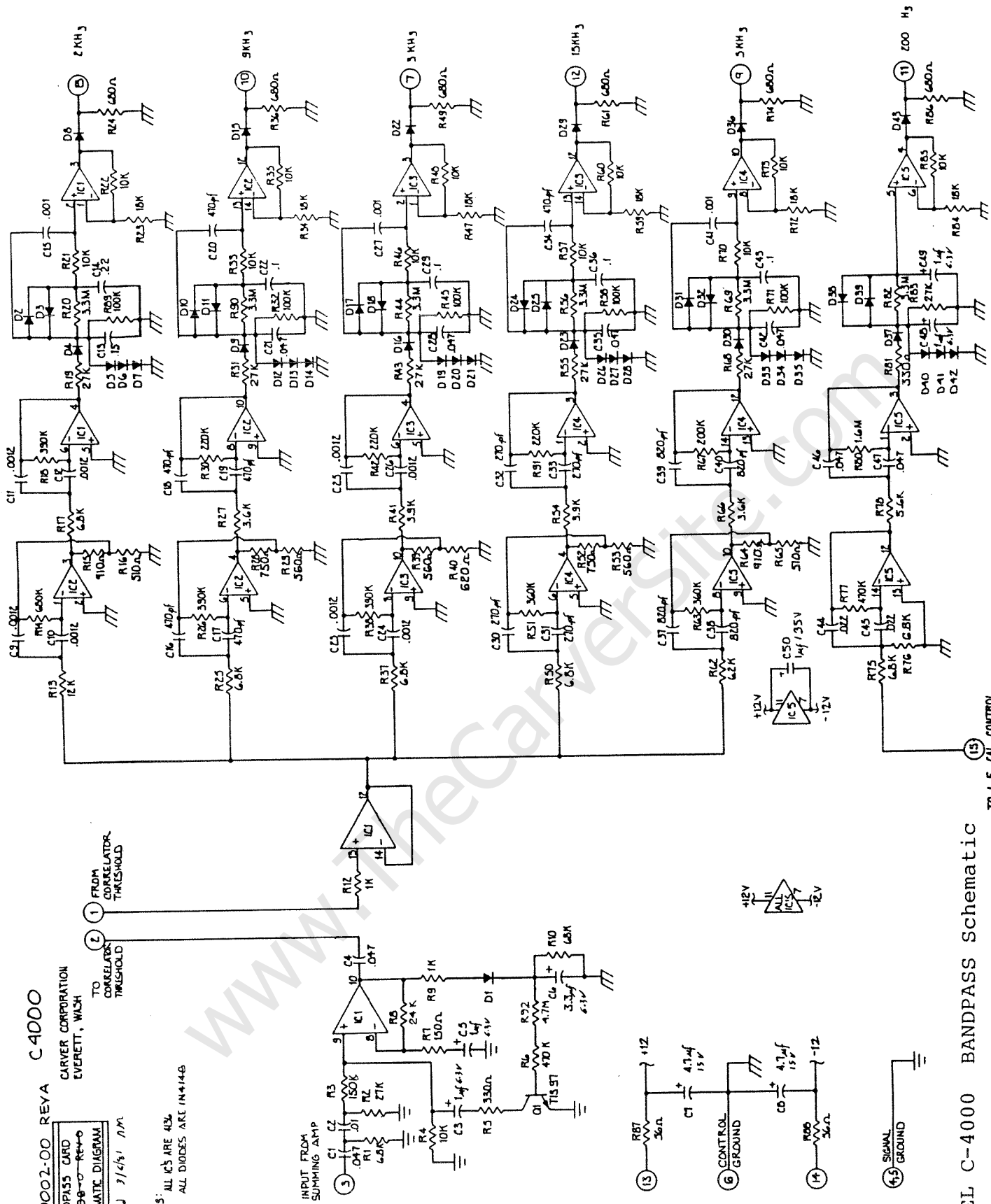

CARVER MODEL C-4000 BANDPASS Schematic

TO L.F. CAL CONTROL

Note: The circuitry on the Bandpass board is part of the Autocorrelator.

ASSEMBLY DIAGRAM
 BANDPASS CARD
 20006 (

ALSO THRESH 50-CENT
 CORRELATOR THRESH-TOP PORT
 INPUT LF CAL TOP PORT
 TSYG GROUND
 CONTROL GROUND
 1 2 3 4 5
 CORRELATOR THRESH-TOP PORT
 INPUT LF CAL TOP PORT
 TSYG GROUND
 CONTROL GROUND
 6 7 8 9 10 11 12 13 14 15
 LF CAL WIPER
 1.12 VOLTS
 1.12 VOLTS
 1.12 VOLTS

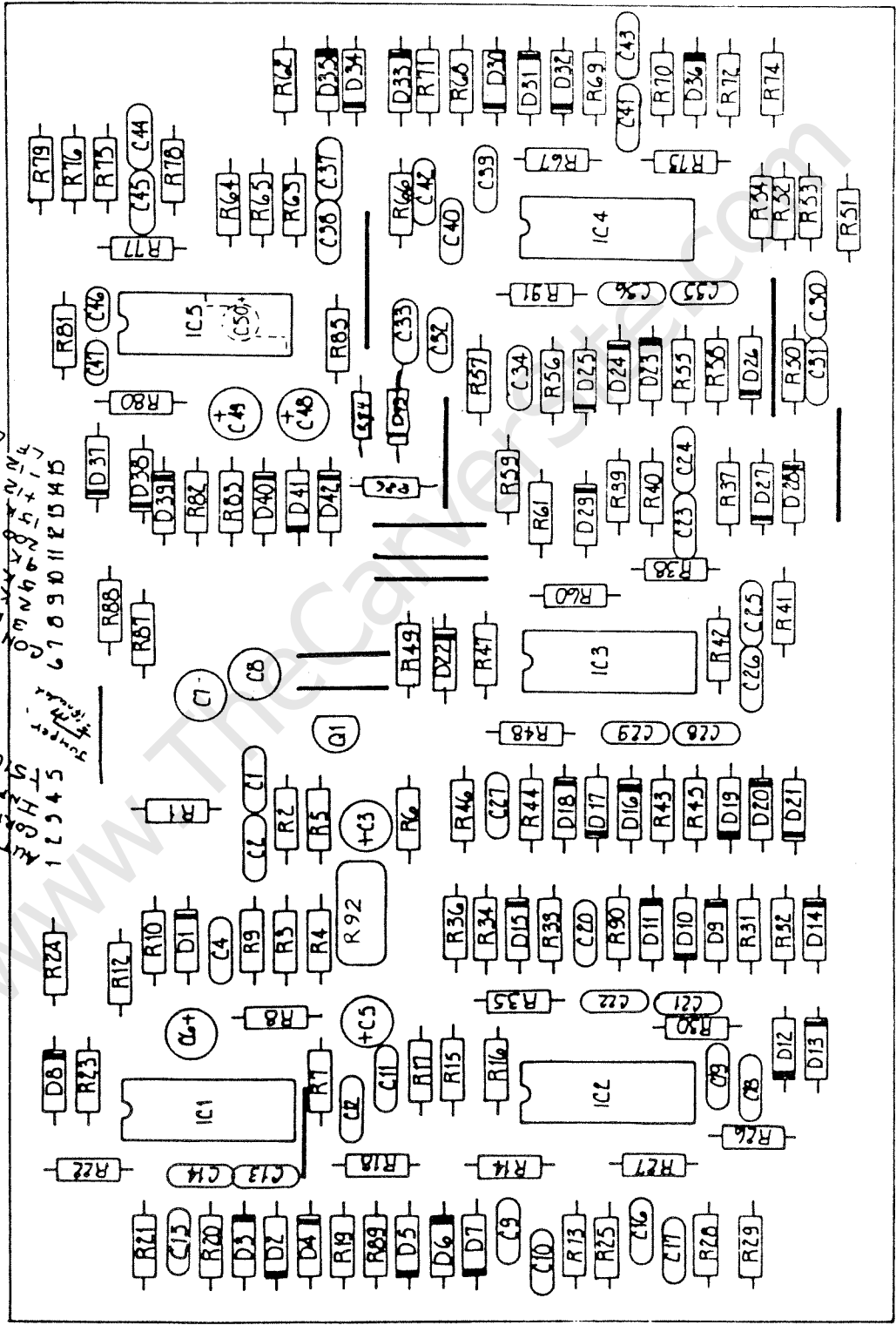

Note: The circuitry on the Bandpass board is part of the Autocorrelator.

CARVER MODEL C-4000 BANDPASS PCB Locator

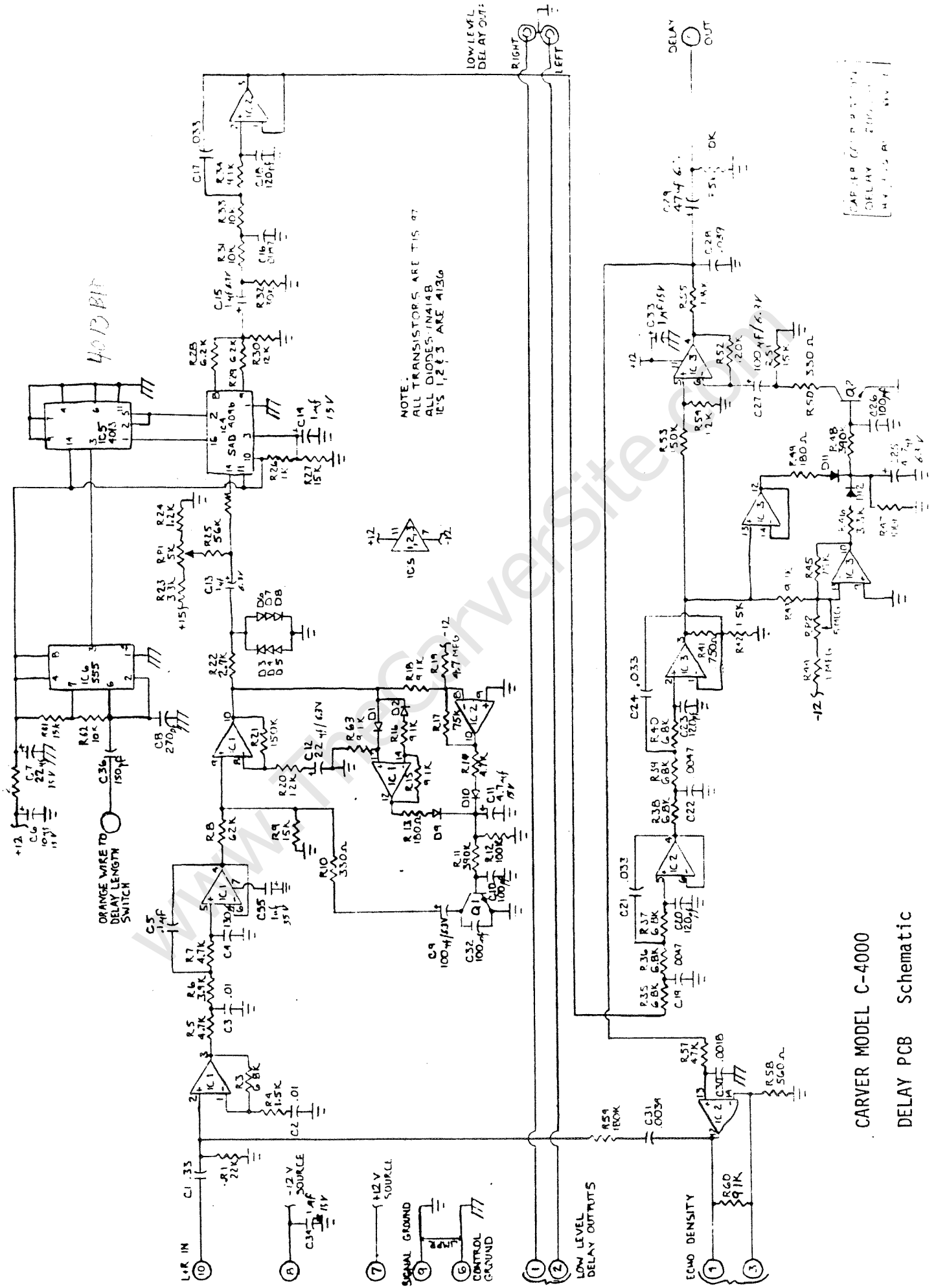

CARVER MODEL C-4000
DELAY PCB Schematic
Old Revision

CAP. 10
DELAY
OK

CARVER MODEL C-4000
 TIME DELAY PCB Parts Locator

CARVER CORP.
 DELAY 20010-1

TO DELAY TIME SWITCH

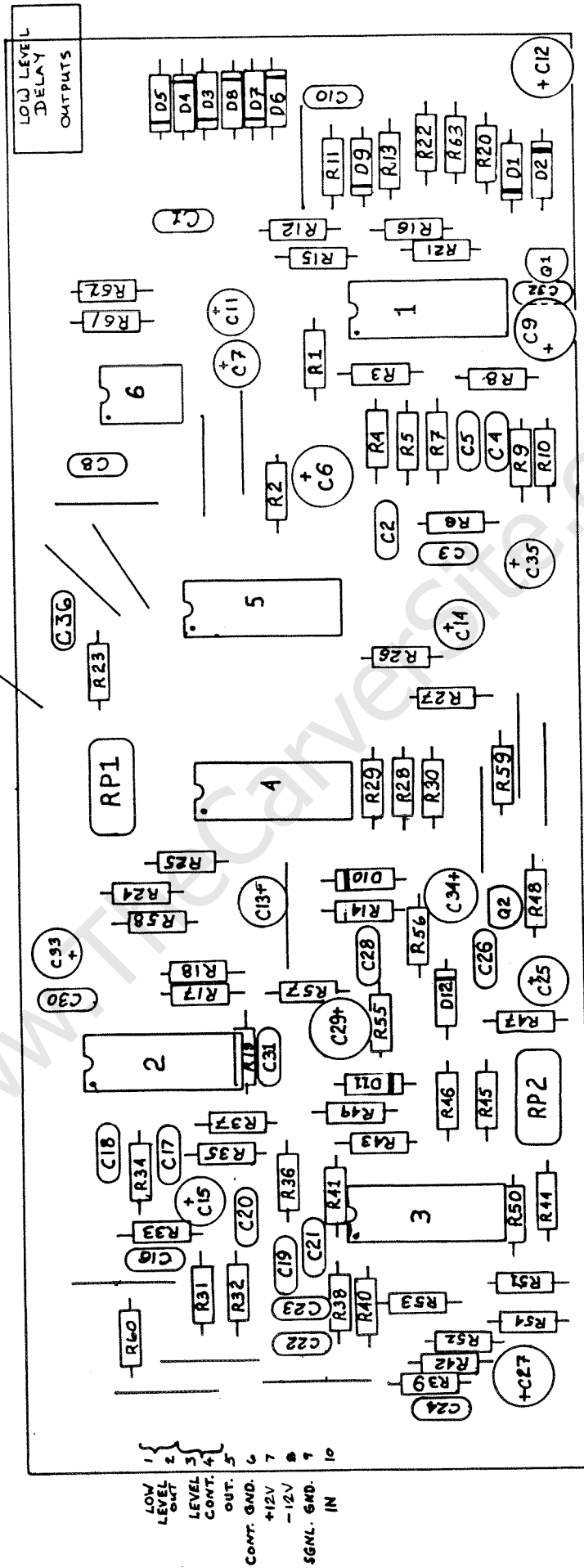

LOW LEVEL
 DELAY
 OUTPUTS

+ C12

C36

RP1

C30
 C33

2

C18
 R34
 C17
 R35
 C15
 R33
 C16
 R31
 R32
 C20
 R36
 C19
 C21
 R38
 R40
 C22
 R39
 R41
 R42
 R43
 R44
 R45
 R46
 R47
 R48
 R49
 R50
 R51
 R52
 R53
 R54
 R55
 R56
 R57
 R58
 R59

C13F

C29+

C28

C27

C24

C25

C26

C27

C28

C29+

C30

C33

C36

C39

C40

C41

C42

C43

C44

C45

C46

C47

C48

C49

C50

C51

C52

C53

C54

C55

C56

C57

C58

C59

C60

C61

C62

C63

C64

C65

C66

C67

C68

C69

C70

C71

C72

C73

C74

C75

C76

C77

C78

C79

C80

C81

C82

C83

C84

C85

C86

C87

C88

C89

C90

C91

C92

C93

C94

C95

C96

C97

C98

C99

C100

C101

C102

C103

C104

C105

C106

C107

C108

C109

C110

C111

C112

C113

C114

C115

C116

C117

C118

C119

C120

C121

C122

C123

C124

C125

C126

C127

C128

C129

C130

C131

C132

C133

C134

C135

C136

C137

C138

C139

C140

C141

C142

C143

C144

C145

C146

C147

C148

C149

C150

C151

C152

C153

C154

C155

C156

C157

C158

C159

C160

C161

C162

C163

C164

C165

C166

C167

C168

C169

C170

C171

C172

C173

C174

C175

C176

C177

C178

C179

C180

C181

C182

C183

| | | |
|--------------------|---------------|-----------|
| CARVER CORPORATION | | |
| C-4000 | TIME DELAY | |
| BOARD# 20010-4 | REV 0 | REVISIONS |
| DRAWN: H J. L. J. | ECO 189 REV 1 | |
| CHECKED: R. M. | ECO 378 REV D | |
| RELEASED: | ECO 381 REV B | |
| | SUBTEST | |
| | SHEET | OF |

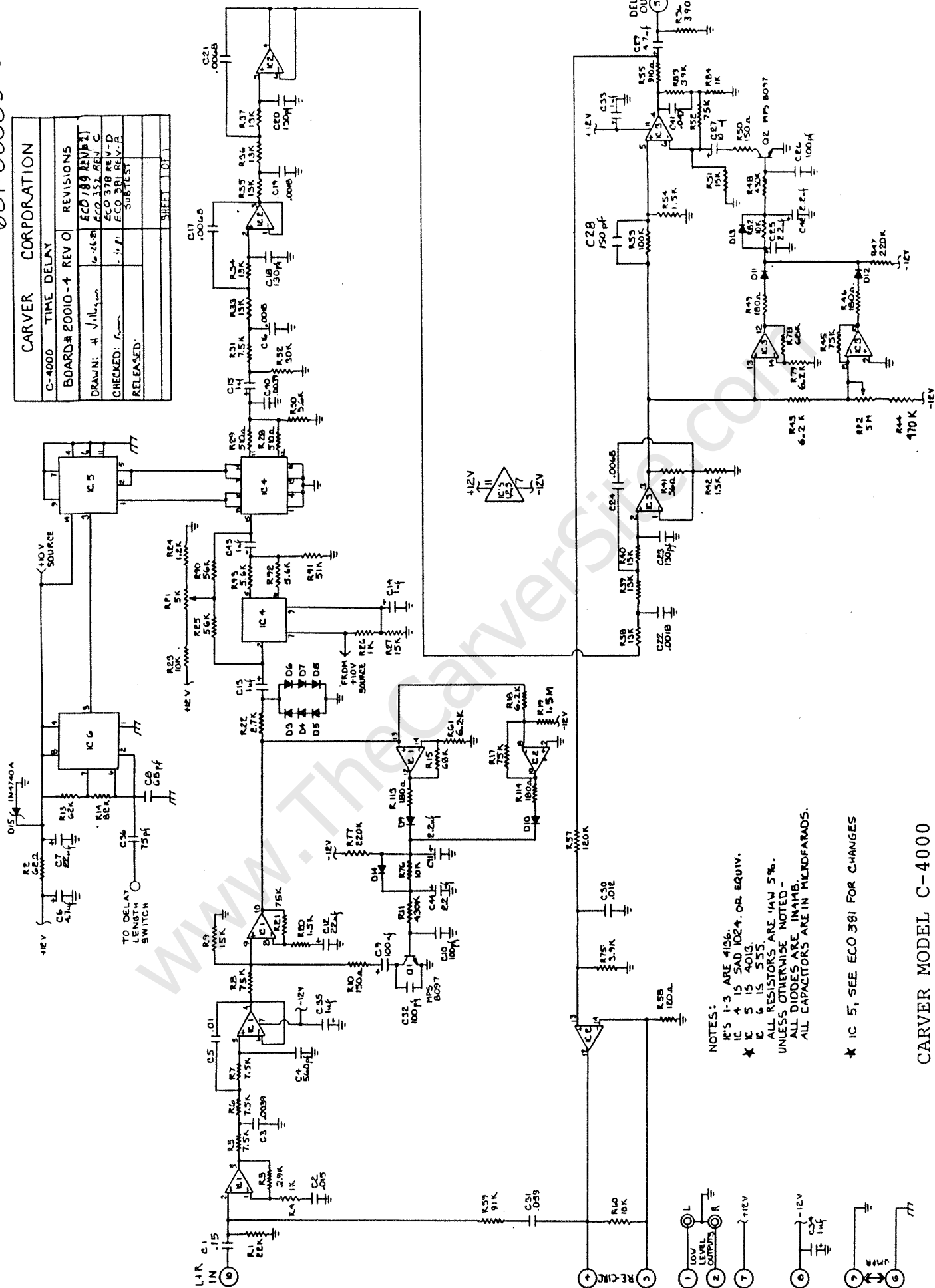

NOTES:
 IC'S 1-3 ARE 4106.
 IC 4 IS 5A0 1024 OR EQUIV.
 IC 5 IS 4013
 IC 6 IS 555
 ALL RESISTORS ARE 1/4W 5%
 UNLESS OTHERWISE NOTED -
 ALL DIODES ARE 1N4148B
 ALL CAPACITORS ARE IN MICROFARADS.

* IC 5, SEE ECO 381 FOR CHANGES

CARVER MODEL C-4000
 DELAY PCB Schematic
 New Revision

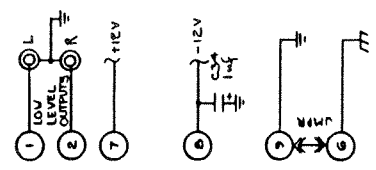

REV LEVELS

TOUCH-UP - 602-ECC'B'

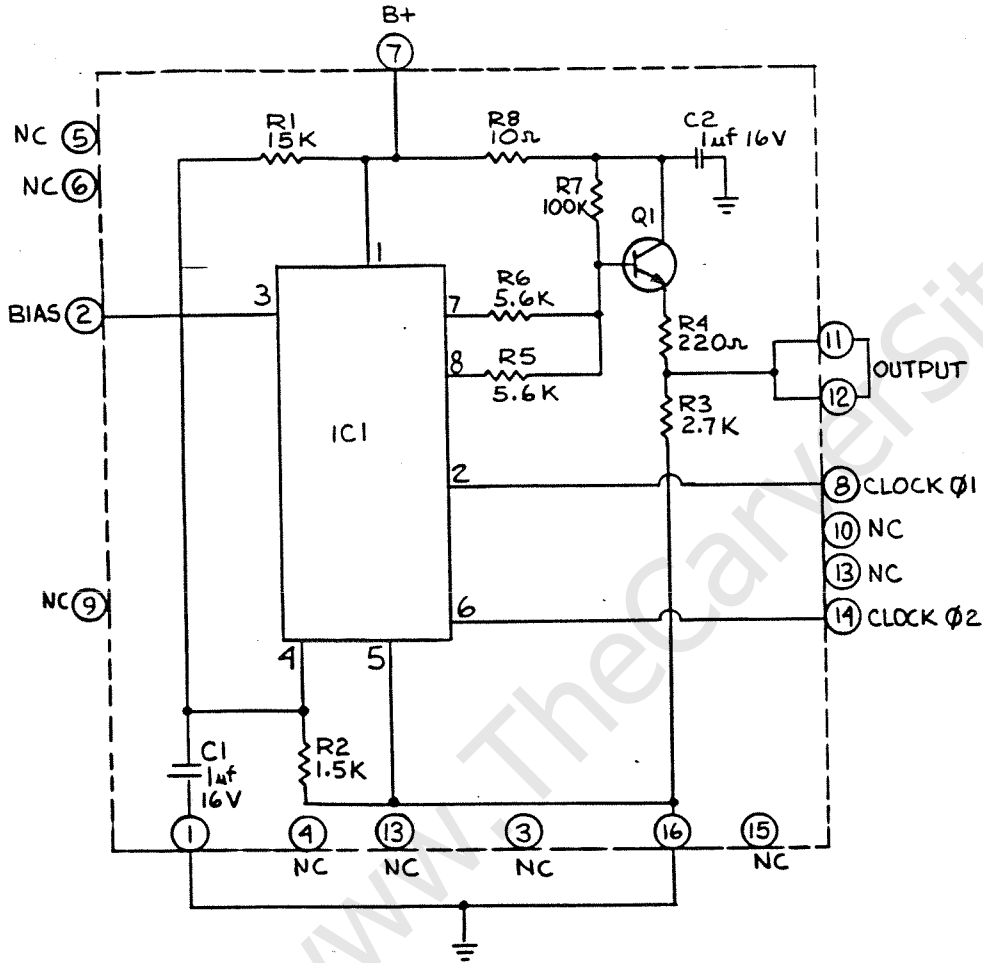

| | |
|--|------------------------------|
| CARVER CORPORATION C-4000 DELAY IC REPLACEMENT BOARD | |
| APPROVALS RAIN TREE 10-11-89 m r 10-21-89 | DATE 10-11-89 10-21-89 |
| SIZE 1.0-21.0 | PRICE NO. 00018-00 |
| SCALE 10F1 | SHEET 1 OF 1 |

6. Tone Amp

| Ref. No | Q'ty | Carver Part No. | Supplier Part No. | Description |
|-----------------------|------|-----------------|-------------------|--------------|
| Semiconductors | | | | |
| IC1 | 1 | | TLO72 | IC |
| IC2 | 1 | | 4136 | IC |
| Capacitors | | | | |
| C1 | 2 | | .12uf | Capacitor |
| C2 | 2 | | 100uf - 6.3v | Electrolytic |
| C3 | 2 | | .003uf | Capacitor |
| C4,5 | 2 | | .039uf | Capacitor |
| C6 | 2 | | 330pf | Capacitor |
| C7,8 | 2 | | .0027uf | Capacitor |
| C9 | 2 | | 22uf - 6.3v | Electrolytic |
| C10 | 2 | | 100pf | Capacitor |
| C11 | 2 | | 27pf | Capacitor |
| C12,13 | 2 | | 22uf - 15v | Electrolytic |
| C14 | 1 | | 10pf | Capacitor |
| Resistors | | | | |
| R1 | 1 | | 33Kohm | Resistor |
| R2 | 1 | | 10Kohm | Resistor |
| R4 | 1 | | 560Kohm | Resistor |
| R7 | 2 | | 27Kohm | Resistor |
| R8,21 | 2 | | 1Kohm | Resistor |
| R9 | 2 | | 1.8Kohm | Resistor |
| R10,12 | 2 | | 3.9Kohm | Resistor |
| R11 | 2 | | 22Mohm | Resistor |
| R13 | 2 | | 4.7Kohm | Resistor |
| R14 | 2 | | 100ohm | Resistor |
| R15 | 2 | | 1.2Kohm | Resistor |
| R16 | 2 | | 2.2Mohm | Resistor |
| R17,18,19 | 2 | | 22Kohm | Resistor |
| R20,30,31,32 | 2 | | 4.7Kohm | Resistor |
| Potentiometers | | | | |
| Bass | 1 | | 50Kohm | |
| Treble | 1 | | 50Kohm | |

CARVER CORPORATION
WOODINVILLE, WA

NOTE:
IC 1 TLO-72
IC 2 4136

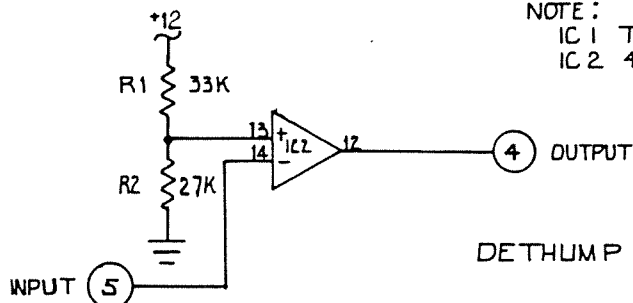

DETHUMP

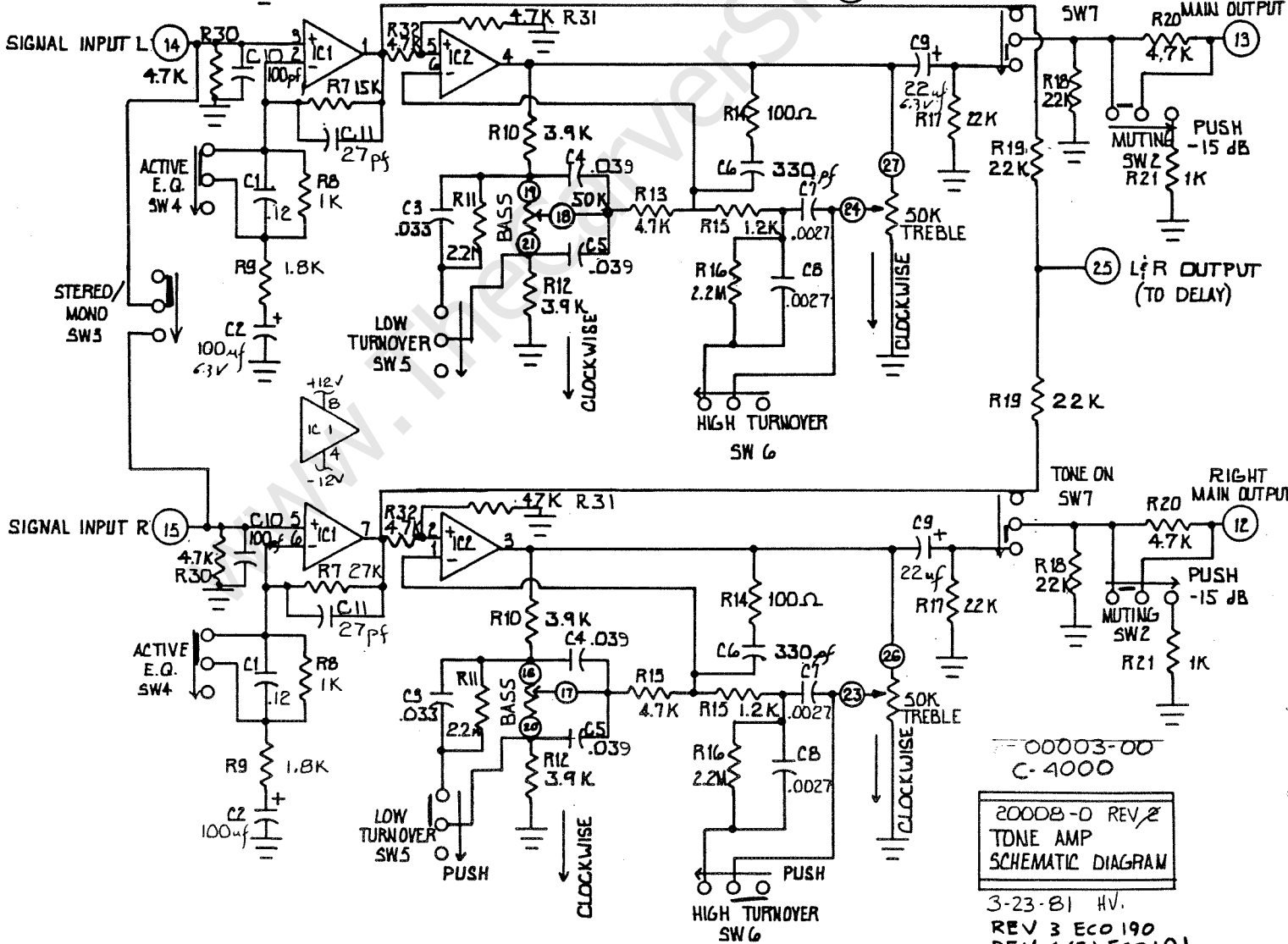
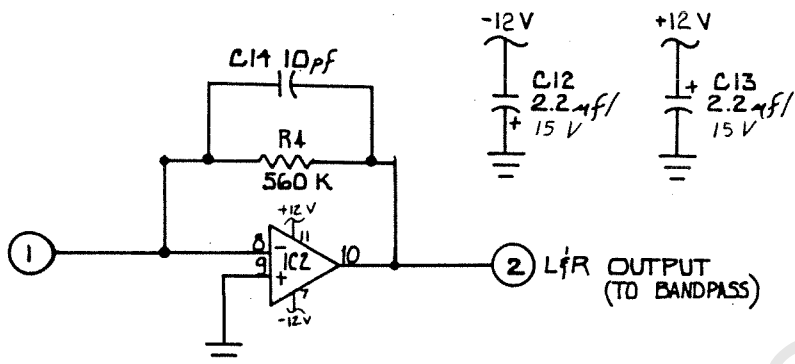
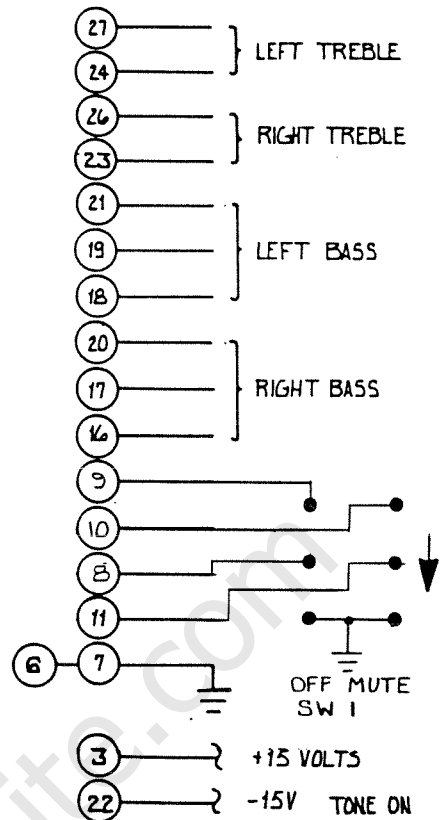

7F00003-00
C-4000

2000B-0 REV 2
TONE AMP
SCHEMATIC DIAGRAM

3-23-81 HV.
REV 3 ECO 190
REV 4 (E) ECO 191

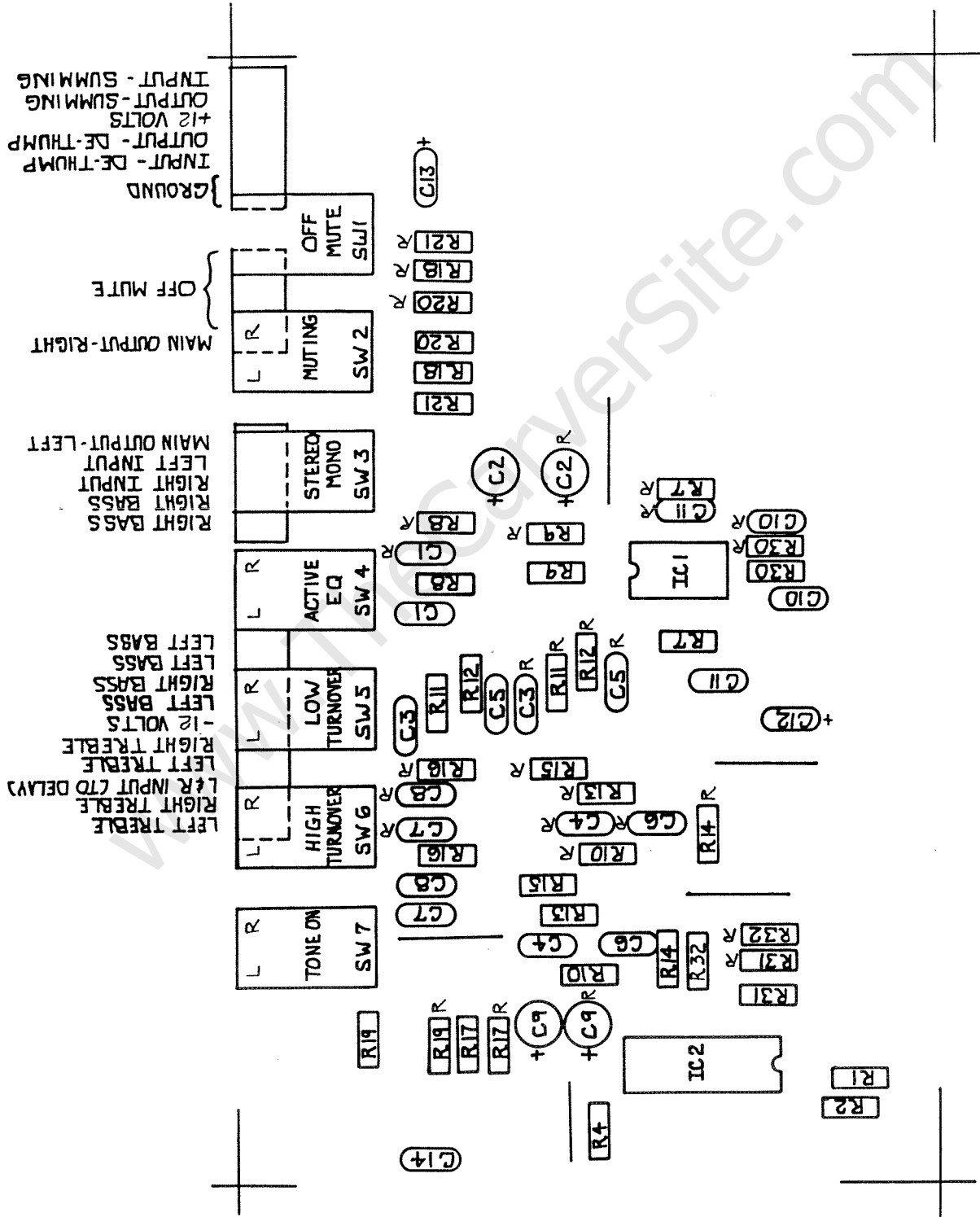

CARVER MODEL C-4000
TONE AMP PCB Parts Locator

1. ALL DIMENSIONS UNLESS OTHERWISE SPECIFIED
 2. ALL DIMENSIONS IN MILLIMETERS
 3. ALL DIMENSIONS UNLESS OTHERWISE SPECIFIED
 4. ALL DIMENSIONS IN MILLIMETERS
 5. ALL DIMENSIONS UNLESS OTHERWISE SPECIFIED
 6. ALL DIMENSIONS IN MILLIMETERS

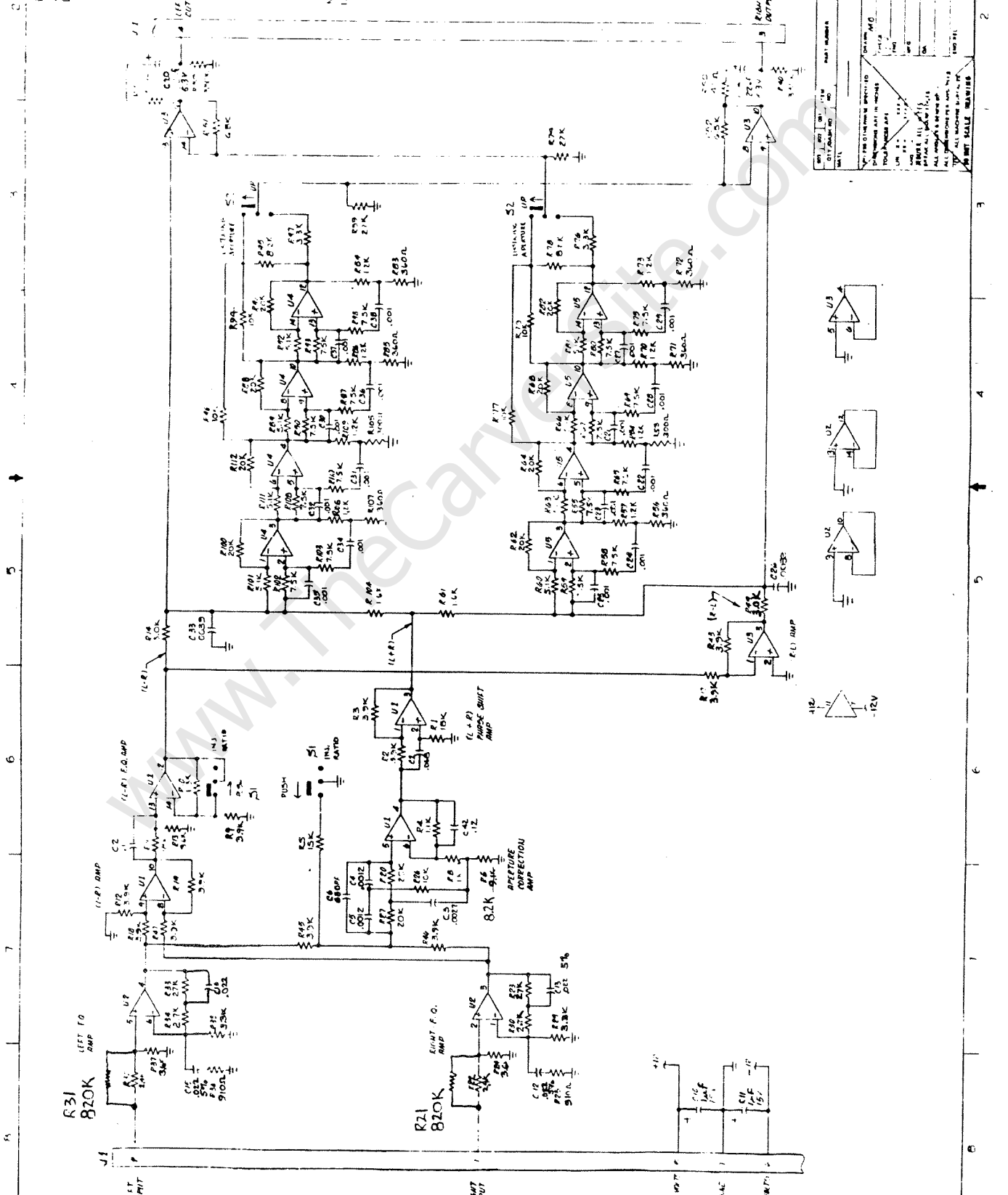

| REV. | DATE | BY | CHKD. | DESCRIPTION |
|------|------|----|-------|----------------|
| 1 | | | | INITIAL DESIGN |
| 2 | | | | REVISED |
| 3 | | | | REVISED |
| 4 | | | | REVISED |
| 5 | | | | REVISED |
| 6 | | | | REVISED |
| 7 | | | | REVISED |
| 8 | | | | REVISED |
| 9 | | | | REVISED |
| 10 | | | | REVISED |
| 11 | | | | REVISED |
| 12 | | | | REVISED |

DRAWING NO. 12-12-12
 TITLE: 12-BIT DIGITAL-TO-ANALOG CONVERTER
 DESIGNED BY: J. J. B. 12-12-12
 CHECKED BY: J. J. B. 12-12-12
 ALL DIMENSIONS UNLESS OTHERWISE SPECIFIED
 ALL DIMENSIONS IN MILLIMETERS
 12-BIT SCALE: 1000

DATE 6-11-80

PRODUCT C-4000

PCB DELAY

SERVICE PRIORITY

All Units

Serial Nos. (specify)

RTS / Dealer Stock

✓ Specific Complaint TOO MUCH / TOO LITTLE ECHO

PROCEDURE

COMPLAINT: "TOO MUCH ECHO [HOWL]", OR "ECHO DENSITY CONTROL HAS TOO LITTLE [NO] EFFECT."

THE MAXIMUM GAIN OF THE OP-AMP WHICH FEEDS BACK DELAY SIGNAL [RECIRCULATION] IS FIXED BY DELAY PCB RESISTOR R60, NOMINAL 9.1 KΩ [SEE DELAY SCHEMATIC].

RECIRC. RUNS AWAY:

1. CHANGE R60 [9.1K] TO 6.8KΩ. VERIFY AUDIBLE ECHO RECIRC. BUT NO HOWL AT FULL-CLOCKWISE ROTATION OF ECHO DENSITY POT.
2. IF HOWL PERSISTS, GO TO NEXT-LOWER RESISTOR VALUE [6.2K, 5.6K] UNTIL HOWL CEASES AT FCW ECHO DENSITY.

INSUFFICIENT RECIRC:

1. CHANGE R60 [9.1K] TO 15KΩ. VERIFY AUDIBLE ECHO BUT NO HOWL AT FCW ECHO DENSITY.
2. IF ECHO REMAINS INADEQUATE, CHANGE R60 TO 30KΩ, OR REMOVE R60 AND LEAVE OFF PCB, IF NECESSARY.
3. IF HOWL OCCURS W/15KΩ, STEP VALUE DOWN UNTIL HOWL STOPS AT FCW ECHO DENSITY.

PART LOCATION:

I/O MOLEX

LOW LEVEL OUT 1
 LEVEL CONT. OUT. 2
 3
 4
 5
 INT. GND. 6
 +15 7
 -15 8
 INL. GND. 9
 IM 10

BOTTOM OF BOARD

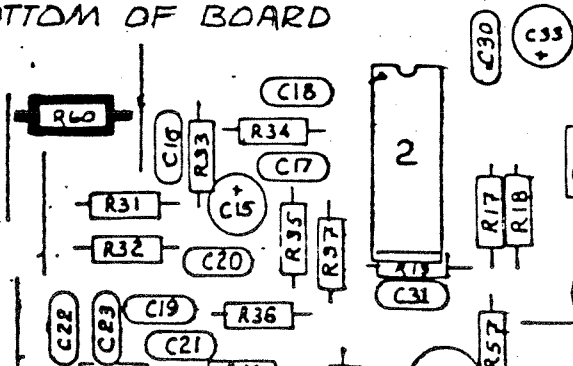

| | | |
|---------------|----------------|-------------|
| DATE 10-13-80 | PRODUCT C-4000 | PCB PWR AMP |
|---------------|----------------|-------------|

| | | |
|------------------|---|--------------------------------------|
| SERVICE PRIORITY | | All Units |
| | | Serial Nos. (specify) |
| | | RTS / Dealer Stock |
| | ✓ | Specific Complaint TURN-OFF "SQUEAL" |

PROCEDURE

UPDATE

ADD 2 EA. 100KΩ AND 200KΩ RESISTORS TO PROVIDE LOCAL NEGATIVE FEEDBACK, STABILIZE PWR AMP AT LESS THAN FULL SUPPLY VOLTAGE.

1. REMOVE TOP AND BOTTOM COVERS.
2. PLACE UNIT ON ITS RIGHT SIDE W/ OPEN BOTTOM FACING YOU.
3. LOCATE FOIL SIDE OF PWR AMP PCB. BOARD MOUNTED BEHIND VOLUME AND BALANCE KTS.
4. LOCATE FOIL PADS OF PREDRIVER TRANSISTORS SHOWN BELOW.
5. TACK-SOLDER RESISTORS TO PADS SHOWN BELOW WITH LARGE CIRCLES.
6. REPLACE BOTTOM, REMOUNT 3 PCB'S BY THEIR RESPECTIVE ANGLE-BRACKETS, REPLACE TOP.

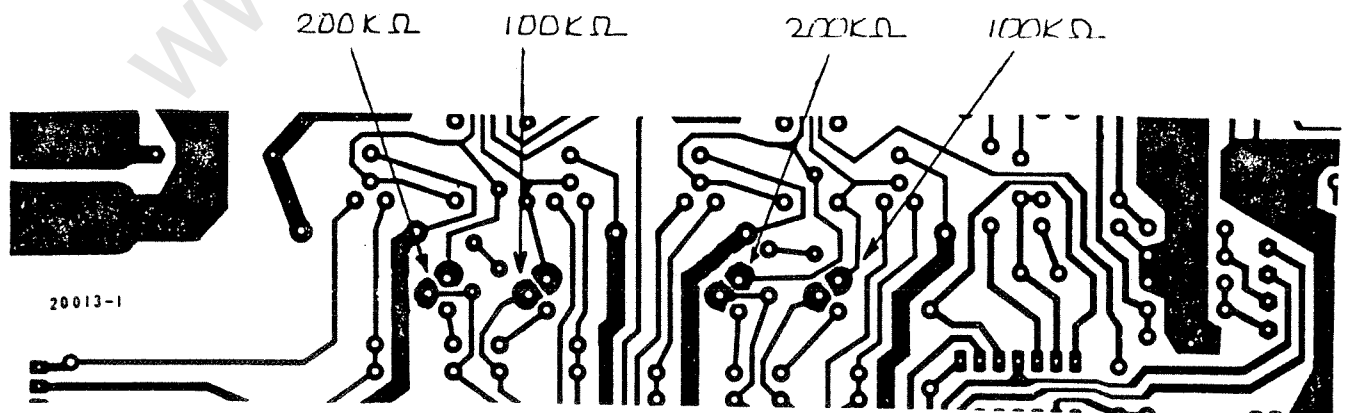

| | | |
|--------------|----------------|------------|
| DATE 1-22-81 | PRODUCT C-4000 | PCB MOTHER |
|--------------|----------------|------------|

| | | |
|------------------|---|----------------------------------|
| SERVICE PRIORITY | | All Units |
| | | Serial Nos. (specify) |
| | | RTS / Dealer Stock |
| | ✓ | Specific Complaint DC ON OUTPUTS |

PROCEDURE

REPLACE DETHUMP FETs.

ONE FET PER CHANNEL IS USED TO "DE-THUMP", OR MUTE TURN-ON AND TURN-OFF THUMPS IN THE C-4000.

A SHORTED JUNCTION IN THE FET WILL PUT AS MUCH AS 1 VOLT OF DC ON THE OUTPUT OF THAT CHANNEL. THE USER SYMPTOMS ARE:

1. BALANCE CONTROL CAUSES POWERFUL LOW-FREQ. THUMP NOISE WHEN ROTATED TO ONE OR THE OTHER EXTREME.
2. HOLOGRAM BUTTON CAUSES LOUD POPS.
3. SHUTDOWN OR ACTIVATION OF POWER AMP PROTECTION CIRCUITS, ESP. WHEN HOLOGRAM IS ENGAGED.

REPAIR:

1. REMOVE TOP-COVER.
2. REMOVE CORRELATOR CIRCUIT CARD (THIRD FROM LEFT).
3. IDENTIFY AND LOCATE FOIL PADS OF DETHUMP FETs:

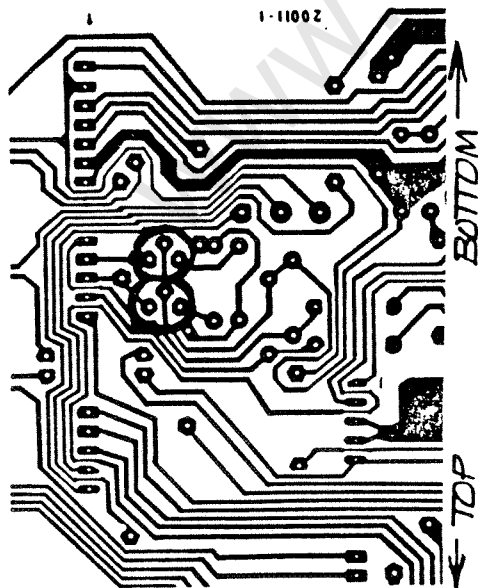

PLACING UNIT FACE-DOWN HELPS.

4. USE WICK TO REMOVE SOLDER.
5. PUSH FET LEADS THROUGH BOARD.
6. TILT UNIT UP AND RECOVER BOTH FETs BEFORE PROCEEDING.
7. INSTALL NEW FETs AS SHOWN:



FET PART NUMBER IS 2N5458.

8. REPLACE CORRELATOR BOARD. MAKE SURE NOT TO MOUNT IT ONE PIN OFF.

9. REPLACE TOP. TEST FOR DC ON OUTPUT OF C-4000.

Revised 2-15-91

| | | |
|-----------------|------------------|-----------|
| DATE 7 - 8 - 81 | PRODUCT C - 4000 | PCB Phono |
|-----------------|------------------|-----------|

| | | |
|------------------|----|----------------------------------|
| SERVICE PRIORITY | | All Units |
| | | Serial Nos. (specify) |
| | | RTS / Dealer Stock |
| | XX | Specific Complaint Gain too high |

PROCEDURE

NOISE OR HUM PROBLEMS, WITH VOLUME DOWN, may be alleviated by reducing the output level of the C-4000. To accomplish this, and reduce the level at Main Output (upper) while leaving Main Output (lower) unaffected, follow this modification procedure:

1. Remove top cover.
2. Locate Phono board (center of unit, main input/output jack buss mounted to rear side of this board. Selector switch also mounts onto this board.
3. Locate two jumper wires which conduct signal from lower to upper Main Outputs, near back of board (see illustration below).
4. Remove these jumpers.
5. Install 6.8k ohm $\frac{1}{4}$ watt resistors in their place,
6. Install 3.6 Kohm $\frac{1}{4}$ watt resistors as shown below, on the foil side of the board, between signal out and ground.
7. Replace top cover.

The upper set of Main Outputs will now have about 10 dB lower output level.

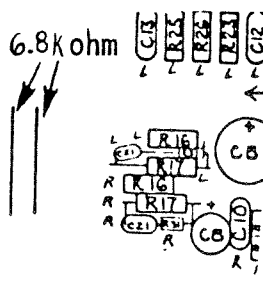
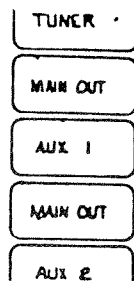

NOTE:
For a 6dB reduction in output level, use 4.3k ohm resistors here and 5.6k ohm resistors here.→

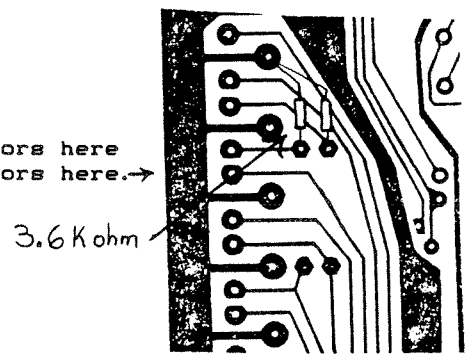

DESIGN HISTORY

Note: This is a partial listing of circuit changes that have occurred in the C-4000 since its inception. Refer to this section if you locate a part in the circuit that is different than that shown in the schematic diagram.

Engineering Change Orders for Model C-4000

ECO #7 DATE: 12/79
REASON FOR CHANGE: Reduce crossover distortion in time delay amplifier.
PROCEDURE: Remove R27L and R27R trim pots on P/S board.
Remove R34L and R34R 1k ohm resistors.
Remove C18L and C18R.
Change C19L and C19R from 150pF to 120pF, and install parallel to R31L and R31R.
Change R28L and R28R from 1k to 1.3K and install one end in the empty pot wiper pad.

ECO #9 DATE: 2/27/80
REASON FOR CHANGE:
PROCEDURE: Change C20L and C20R from .022uF to .33uF on P/S Bd.

ECO #10 DATE: 2/27/80
REASON FOR CHANGE: Correct Group Delay.
PROCEDURE: Change C8 from 240pF to 270pF on Delay Board.
Change C28 from .018uF to .039uF.
Change C36 from 270pF to 150pF.
Change R13 from 27k to 15k.
Change R14 from 22k to 10k.

ECO #43 DATE: 8/6/80
REASON FOR CHANGE: Implement Type B Hologram circuit.
PROCEDURE: Change Hologram board from 20012-2 to 20012-5.
Note: S/N followed by letter "C" indicates Type B.

ECO #74 DATE: 12/27/80
REASON FOR CHANGE: Improve reliability.
PROCEDURE: On P/S board:
Change VR1 & VR2 from 15 volt regulators to 12 volt regulators [LM340T-12(+12V) and LM320T-12(-12V)].
Install 75 ohm 2W resistors across regulators (Input to Output). (Refer to ECO #348).
Replace transformer with 12V version, P/N PKH1-1098.

www.TheCarverSite.com

©Copyright 1992 CARVER CORPORATION
ALL RIGHTS RESERVED

Printed in U.S.A.

P/N 990-20001-01
Rev. C